

**INSTALLER: LEAVE THIS MANUAL WITH THE APPLIANCE.
CONSUMER: RETAIN THIS MANUAL FOR FUTURE REFERENCE.**



INSTALLATION AND OPERATING INSTRUCTIONS

CERTIFIED UNDER U.S. ENVIRONMENTAL PROTECTION AGENCY (E.P.A.) JULY 1990 40 C.F. R. PART 60 AND THE OREGON DEPARTMENT OF ENVIRONMENTAL QUALITY (D.E.Q.) PARTICULATE EMISSION STANDARDS BY E.E.M.C THESE STOVES HAVE BEEN TESTED AND LISTED BY INTERTEK TESTING SERVICES TO STANDARDS: CSA B366.2, ULC S627, UL 1482.

2300 PEDESTAL MODEL

SAFETY INFORMATION

WARNING

If the information in these instructions is not followed exactly, a fire or explosion may result causing property damage, personal injury or death. Improper installation, adjustment, alteration, service or maintenance can cause injury or property damage, bodily injury or even death. Please read entire manual before you install and use your appliance.

This appliance has not been tested with an unvented gas log set. To reduce risk of fire or injury, do not install an unvented gas log set into the appliance.

- This appliance can be very hot when burning.
- Combustible materials such as firewood, wet clothing, etc. placed too close can catch fire.
- Children and pets must be kept from touching the appliance when it is hot.
- The chimney must be sound and free of cracks. Before installing this unit, contact the local building or fire authority and follow their guidelines.
- Operate only with the door tightly closed.
- Burn wood behind the log retainer directly on the firebricks.
- Do not use an elevated grate or otherwise raise the fire.
- At least 14 square inches of outside air must be admitted to the room or directly to the unit through a 4" diameter pipe.
- This appliance is designed to burn natural wood only. Higher efficiencies and lower emissions generally result when burning air dried seasoned hardwoods, as compared to softwoods or to green or freshly cut hardwoods.
- Do not start a fire with chemicals or fluids such as gasoline, engine oil, etc.
- Do not burn treated wood, coal, charcoal, colored paper, cardboard, solvents or garbage.
- Do not let the appliance become hot enough for any part to glow red.
- **KEEP THE STOVE TOP TEMPERATURE BELOW 700°F (371°C).** Attempts to achieve heat output rates that exceed design specifications can result in steel distortion and damage.

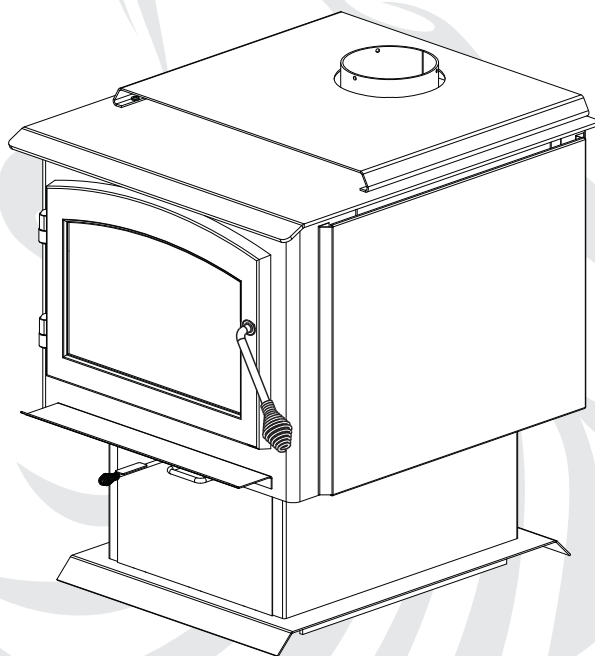

APPLY SERIAL NUMBER LABEL FROM CARTON



Wolf Steel Ltd., 24 Napoleon Rd., Barrie, ON, L4M 4Y8 Canada /
103 Miller Drive, Crittenden, Kentucky, USA, 41030
Phone (705)721-1212 • Fax (705)722-6031 • www.timberwolfireplaces.com • ask@timberwolfireplaces.com

TABLE OF CONTENTS

1.0	INSTALLATION OVERVIEW	3
2.0	INTRODUCTION	4
2.1	DIMENSIONS	5
2.2	SPECIFICATIONS	5
2.3	GENERAL INSTRUCTIONS	5
2.4	GENERAL INFORMATION	6
2.5	RATING PLATE LOCATION	7
3.0	PRE-INSTALLATION PREPARATION	8
3.1	APPLIANCE PLACEMENT	8
3.2	CLEARANCE TO COMBUSTIBLES	8
3.3	FLOOR PROTECTION	8
3.4	OUTSIDE AIR	9
4.0	INSTALLATION	10
4.1	CHIMNEY	11
4.1.1	CHIMNEY CONNECTION	12
4.1.2	ADDING SECTIONS	13
4.1.3	TYPICAL THROUGH THE CEILING	14
4.1.4	TYPICAL THROUGH THE WALL	15
4.1.5	TYPICAL EXISTING MASONRY	16
5.0	FINISHING	17
5.1	DOOR REMOVAL / INSTALLATION	17
5.2	DOOR HANDLE INSTALLATION	17
5.3	BRICKS AND BAFFLE INSTALLATION	18
6.0	OPTIONAL KIT INSTALLATIONS	19
6.1	OPTIONAL BLOWER INSTALLATION	19
7.0	OPERATION	20
7.1	AIR CONTROL	21
7.2	FIRE EXTINGUISHERS / SMOKE DETECTORS	21
7.3	FUEL	22
7.4	LIGHTING A FIRE	22
7.4.1	FLASH FIRE	22
7.4.2	EXTENDED FIRE	22
7.5	SMOKING	22
8.0	MAINTENANCE	23
8.1	ASH REMOVAL PROCEDURES	23
8.2	CREOSOTE FORMATION AND REMOVAL	24
8.3	RUNAWAY OR CHIMNEY FIRE	24
8.4	CHIMNEY CLEANING	24
8.5	GLASS REPLACEMENT	25
8.6	GASKET REPLACEMENT	25
8.7	CARE OF GLASS	26
8.8	CARE OF PLATED PARTS	26
8.9	WOOD	26
9.0	REPLACEMENTS	27
10.0	TROUBLE SHOOTING	29
11.0	WARRANTY	30
12.0	SERVICE HISTORY	31
13.0	NOTES	32

NOTE: Changes, other than editorial, are denoted by a vertical line in the margin.

1.0 INSTALLATION OVERVIEW

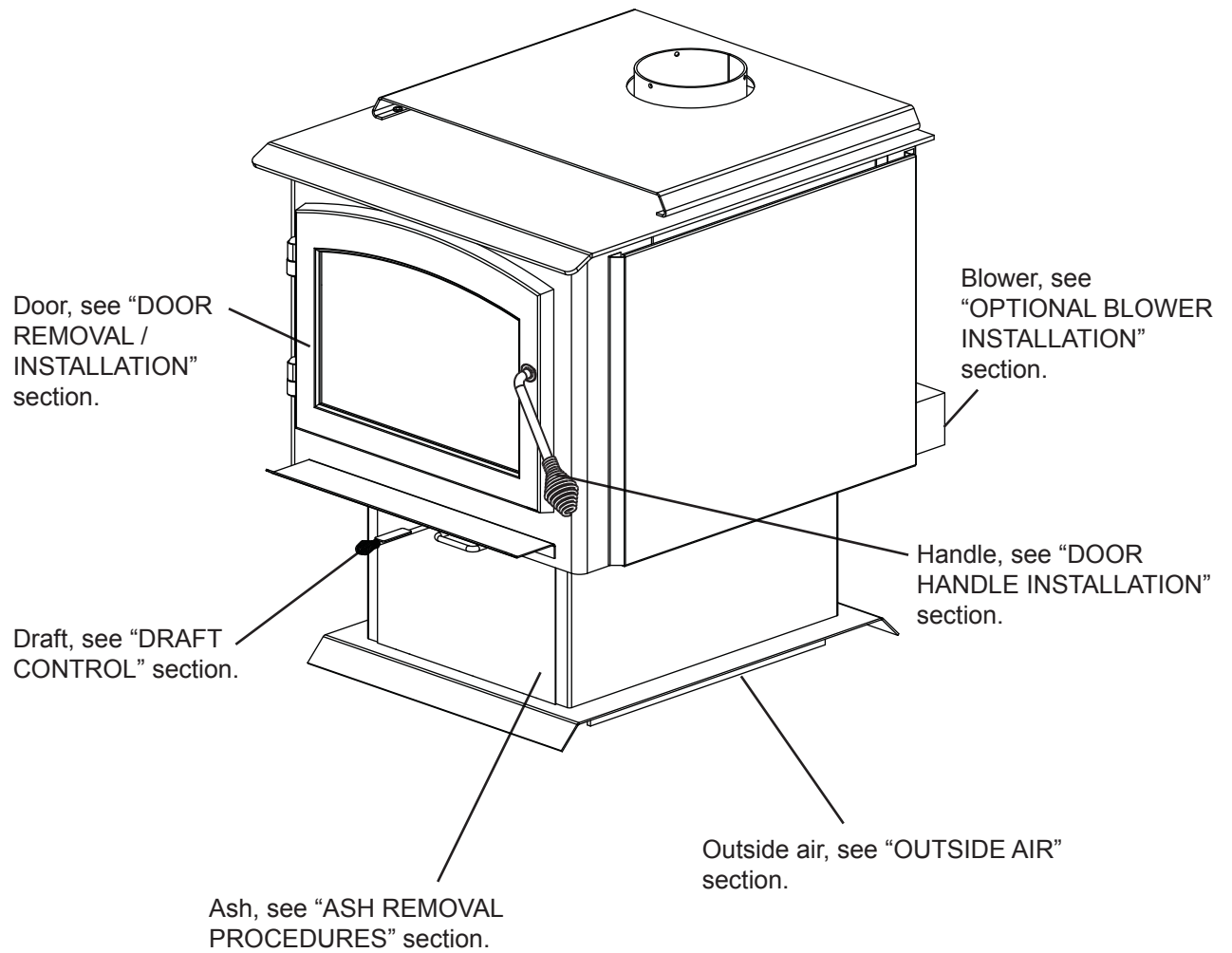

2.0 INTRODUCTION

WARNING

- **THIS APPLIANCE IS HOT WHEN OPERATED AND CAN CAUSE SEVERE BURNS IF CONTACTED.**
- Do not operate appliance before reading and understanding operating instructions. Failure to operate appliance according to operating instructions could cause fire or injury.
- Before installing this appliance, contact the local building or fire authority and follow their guidelines.
- This appliance must be installed by a qualified installer.
- Risk of burns. The appliance should be turned off and cooled before servicing.
- Do not let the appliance become hot enough for any part to glow red.
- Do not install damaged, incomplete or substitute components.
- Risk of cuts and abrasions. Wear protective gloves and safety glasses during installation. Sheet metal edges may be sharp.
- Young children should be carefully supervised when they are in the same room as the appliance. Toddlers, young children and others may be susceptible to accidental contact burns. A physical barrier is recommended if there are at risk individuals in the house. To restrict access to an appliance or stove, install an adjustable safety gate to keep toddlers, young children and other at risk individuals out of the room and away from hot surfaces.
- Clothing or other flammable material should not be placed on or near the appliance. Objects placed in front of the appliance must be kept a minimum of 48" away from the front face of the appliance.
- Due to high temperatures, the appliance should be located out of traffic and away from furniture and draperies.
- Ensure you have incorporated adequate safety measure to protect infants/toddlers from touching hot surfaces.
- Even after the appliance is out, the glass and/or screen will remain hot for an extended period of time.
- Check with your local hearth specialty dealer for safety screens and hearth guards to protect children from hot surfaces. These screens and guards must be fastened to the floor.
- Any safety screen or guard removed for servicing must be replaced prior to operating the appliance.
- Under no circumstances should this appliance be modified.
- Do not operate the appliance with the glass door removed, cracked or broken. Replacement of the glass should be done by a licensed or qualified service person.
- Do not strike or slam shut the appliance glass door.
- Operate only with the doors tightly closed.
- Only doors / optional fronts certified with the unit are to be installed on the appliance.
- Keep the packaging material out of reach of children and dispose of the material in a safe manner. As with all plastic bags, these are not toys and should be kept away from children and infants.
- If the appliance is not properly installed, a house fire may result. Do not expose the appliance to the elements (ex. rain, etc.) and keep the appliance dry at all times. Wet insulation will produce an odour when the appliance is used.
- The chimney must be sound and free of cracks. Clean your chimney a minimum of twice a year and as required.
- Do not start a fire with chemicals or fluids such as gasoline, engine oil, etc.
- Your appliance requires periodic maintenance and cleaning. Failure to maintain your appliance may lead to smoke spillage in your home.
- Higher efficiencies and lower emissions generally result when burning air dried seasoned hardwoods, as compared to softwoods or too green or freshly cut hardwoods. Burning wet unseasoned wood can cause excessive creosote accumulation. When this is ignited it can cause a chimney fire that may result in a serious house fire.
- This appliance is designed to burn natural wood only. Do not burn treated wood, coal, charcoal, coloured paper, cardboard, solvents or garbage.
- Burn wood behind the log retainer directly on the firebricks. Do not elevate grate or otherwise raise the fire.
- Do not store wood within appliance installation clearances or within the space required for re-fueling and ash removal.

3.17A

2.1 DIMENSIONS

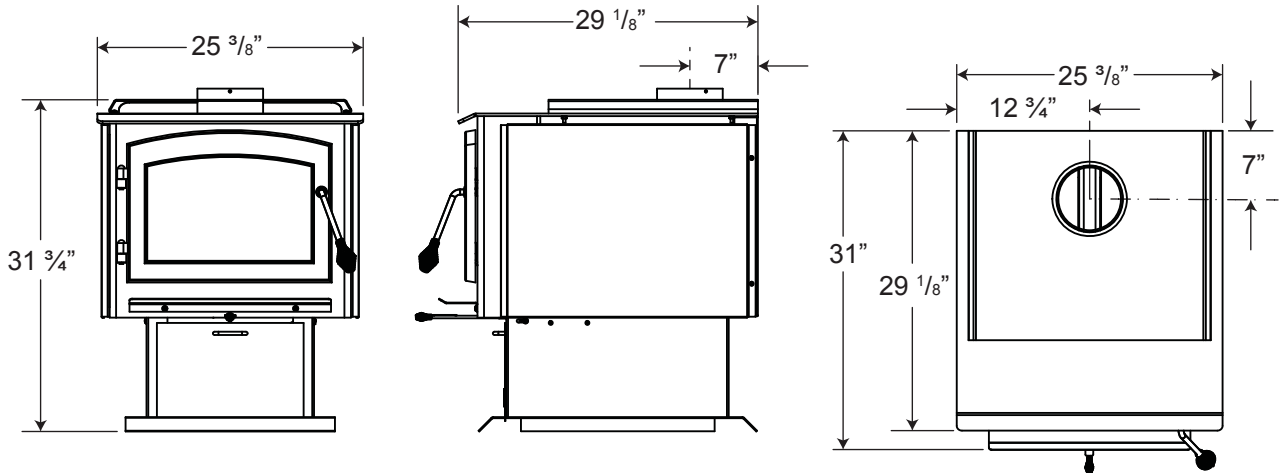

2.2 SPECIFICATIONS

SPECIFICATIONS	2300
CHAMBER (D.W.H)	22 1/2" x 18" x 12"
CAPACITY	3.0 FT ³
APPROX. AREA HEATED*	1000-3500 FT ²
HEAT OUTPUT (HIGH BURN) **	85,000 BTU
DURATION LOW FIRE*	12 HRS
WEIGHT w/o BRICKS	285 LBS
WEIGHT OF BRICKS	114 LBS
IDEAL WOOD LENGTH	21"

* Figures will vary considerably with individual conditions.

** Wolf Steel Ltd. estimated realistic BTU/h with hardwood logs and regular refueling.

2.3 GENERAL INSTRUCTIONS

! WARNING

ALL WIRING SHOULD BE DONE BY A QUALIFIED ELECTRICIAN AND SHALL BE IN COMPLIANCE WITH LOCAL CODES. IN THE ABSENCE OF LOCAL CODES, USE THE CURRENT CSA22.1 CANADIAN ELECTRIC CODE IN CANADA OR THE CURRENT NATIONAL ELECTRIC CODE ANSI/NFPA NO. 70 IN THE UNITED STATES.

THIS APPLIANCE HAS NOT BEEN TESTED WITH ANY VENTED OR UNVENTED GAS LOG SET. TO REDUCE RISK OF FIRE OR PREVENT INJURY, DO NOT INSTALL A VENTED OR UNVENTED GAS LOG SET INTO THE APPLIANCE.

BURNING YOUR UNIT WITH THE ASH DUMP DOOR OPEN OR AJAR CREATES A FIRE HAZARD THAT MAY RESULT IN DISCOLOURATION TO THE GOLD PLATED DOOR, INTERNAL DAMAGE TO THE APPLIANCE OR A HOUSE CHIMNEY FIRE.

DO NOT CONNECT THIS APPLIANCE TO A CHIMNEY FLUE SERVING ANOTHER APPLIANCE.

THIS APPLIANCE AND IT'S COMPONENTS ARE DESIGNED TO BE INSTALLED AND OPERATED AS A SYSTEM. ANY ALTERATION TO OR SUBSTITUTION FOR ITEMS IN THIS SYSTEM, UNLESS ALLOWED BY THESE INSTALLATION INSTRUCTIONS, WILL VOID THE LISTING AND MAY VOID THE PRODUCT WARRANTY. IT MAY ALSO CREATE A HAZARDOUS INSTALLATION. READ THROUGH THESE INSTRUCTIONS THOROUGHLY BEFORE STARTING YOUR INSTALLATION AND FOLLOW THEM CAREFULLY THROUGHOUT YOUR PROJECT.

- Before beginning your installation, consult with your local building code agency or fire officials and insurance representative to ensure compliance.
- Non-toxic smoke will be emitted during the paint curing process, to help dissipate the smoke open a window near the appliance.
- Remove any dust or debris off the top of the appliance before firing the appliance as the paint will become soft as the appliance heats up and will harden as the appliance cures. To cure the paint on your appliance burn your appliance moderately hot during the first few fires.
- To keep the gasket from sticking to the appliance as the paint is curing, periodically open the door every 5-10 minutes.
- For the first two weeks use generous amounts of fuel and burn the appliance with the damper wide open for an hour as the appliance goes through a process of eliminating moisture in the steel and firebricks. The initial heat output will be reduced while the moisture is being drawn from the appliance and it will be necessary to build several hot fires to remove this moisture. **DURING THIS PROCESS DO NOT OVERFIRE THE APPLIANCE. REDUCE THE AMOUNT OF AIR COMING INTO THE APPLIANCE IF THE APPLIANCE OR CHIMNEY BECOMES RED.**

2.4 GENERAL INFORMATION

! WARNING

DO NOT OPERATE THIS APPLIANCE WITHOUT THE PEDESTAL INSTALLED.

Your appliance has been specifically designed over many months of research to meet the 1990 U.S.A. EPA particulate emission standards and have been extensively tested in Canadian and American laboratories. This system is the most efficient, simple and trouble free we know and works as follows:

The chimney vent system used on your wood burning appliance should be designed with the least amount of restriction possible to enable the exhaust products to easily flow through it. Chimney vent systems that are too short or too long can also have an adverse affect on the flow of exhaust through it. The wood burning appliance and chimney vent system also require a sufficient supply of combustion air not only to support the combustion in the combustion chamber but to replace the exhaust leaving it so it can flow freely up through the vent system and out into the atmosphere. It is the correct balance of combustion air and the chimney vent system that will ensure the appliance provides you with its optimum performance.

Combustion air enters through two holes in the bottom which can be adjusted by a single air control. Air from the front hole goes up on either side of the door into a preheating airwash located across the top and then down the window to feed the fire and also to ensure that the glass remains clean. Air from this hole also feeds directly into the combustion chamber at hearth level. Secondary air from the rear hole travels up the back in the secondary air housing to the manifold located at the top and shoots out laterally to oxidize the gases below the smoke exit. The combustion chamber is lined with high temperature firebrick on 2 sides, the back and across the bottom, with a layer of fibre baffles at the top to maintain a high temperature in the combustion chamber so that gases mixing with the preheated air from the secondary air manifold tube are easily ignited and burned. The stove sides and back are shielded to direct the heat upwards and forwards into the room.

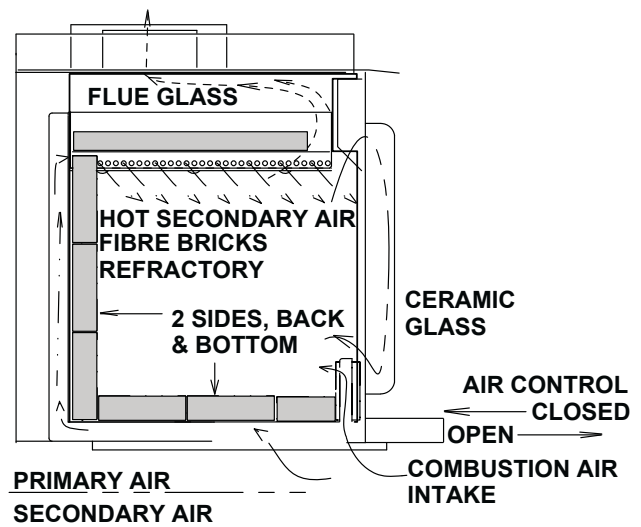

Be sure to provide sufficient combustion air. There are many other appliances in your home competing for air such as: a kitchen range hood, forced air heating devices or a bathroom exhaust fan.

Expansion / contraction noises during heating up and cooling down cycles are normal and to be expected.

After extended periods of non-operation such as following a vacation or a warm weather season, the appliance may emit a slight odour for a few hours. This is caused by dust particles on the firebox burning off. Open a window to sufficiently ventilate the room.

CALIFORNIA PROP 65 WARNING:

Use of this product may produce smoke which contains chemicals known to the State of California to cause cancer, birth defects, or other reproductive harm.

If optional ash drawer is purchased, ensure that the ash dump door is tightly closed, allow the door to snap shut dislodging anything (ashes or pieces of coal) that may be stuck in the opening.

If outside air is utilized, you should never experience a shortage of combustion air. If you choose not to utilize outside air and experience draft or smoking problems, you may need to open a door, a window or otherwise provide some method of supplying combustion air to the appliance.

2.5 RATING PLATE LOCATION

For rating plate location, see "INSTALLATION OVERVIEW" section.



We suggest that our woodburning hearth products be installed and serviced by professionals who are certified in the U.S. by the National Fireplace Institute® (NFI) as NFI Woodburning Specialists or who are certified in Canada by Wood Energy Technical Training (WETT).





Intertek
REFERENCE #15983

INSTALL AND USE ONLY IN ACCORDANCE WITH THE MANUFACTURER'S INSTRUCTIONS AND LOCAL BUILDING CODES. MINIMUM CEILING HEIGHT: 7FT (2.13m)

HEARTH EXTENSION / COMBUSTIBLE FLOOR PROTECTION: IF INSTALLED ON A COMBUSTIBLE FLOOR, UNIT MUST BE PLACED ON A NON-COMBUSTIBLE FLOOR PROTECTOR EXTENDING 18" (455mm) IN FRONT AND 8" (205mm) TO THE SIDES AND BACK.

CHIMNEY TYPE: MINIMUM 6" (152mm) DIAMETER APPROVED RESIDENTIAL TYPE FOR MOBILE HOME USE A CHIMNEY LISTED TO ULC S629 IN CANADA OR UL 103HT IN THE USA.

CHIMNEY CONNECTOR: 6" (152mm) DIAMETER MINIMUM 24 GAUGE STEEL MINIMUM CLEARANCE FROM HORIZONTAL CONNECTOR AND CEILING 18" (455mm). DO NOT OBSTRUCT SPACE UNDER HEATER. SPECIAL METHODS ARE REQUIRED WHEN PASSING A CHIMNEY THROUGH A WALL OR CEILING. SEE INSTRUCTIONS AND BUILDING CODES. DO NOT CONNECT THIS UNIT TO A CHIMNEY FLUE SERVING ANOTHER APPLIANCE.

FUEL: FOR USE WITH WOOD ONLY. DO NOT USE GRATE OR ELEVATE FIRE. BUILD WOOD FIRE DIRECTLY ON HEARTH.

WARNING: RISK OF SMOKE SPILLAGE. OPERATE ONLY WITH DOOR FULLY CLOSED. REPLACE GLASS ONLY WITH CERAMIC GLASS. DO NOT OVERFIRE. IF HEATER OR CHIMNEY CONNECTORS GLOW, YOU ARE OVERFIRING. INSPECT AND CLEAN CHIMNEY FREQUENTLY. UNDER CERTAIN CONDITIONS OF USE CREOSOTE BUILD-UP MAY OCCUR RAPIDLY.

OPTIONAL BLOWER KIT: EP-62, 115V, 60HZ, 0.82AMP. ROUTE CORD AWAY FROM UNIT.

DANGER: RISK OF ELECTRICAL SHOCK. DISCONNECT POWER BEFORE SERVICING UNIT.

LISTED SOLID FUEL BURNING SPACE HEATER / POÊLE À COMBUSTIBLE SOLIDE HOMOLOGUÉE
TESTED TO: / TESTÉ SELON : UL1482 / ULC S627 / CSA B366.2 (DEC 92)
MODEL / MODÈLE - EPA 1900



CONTACT LOCAL BUILDING FIRE OFFICIALS ABOUT RESTRICTIONS AND INSTALLATION INSPECTIONS IN YOUR LOCAL AREA. A MINIMUM CLEARANCE OF 18 INCHES (457mm) TO THE CHIMNEY CONNECTOR MAY BE REQUIRED BY THE AUTHORITY HAVING JURISDICTION.

RENSEIGNEZ-VOUS AUPRÈS DES AUTORITÉS LOCALES DU BÂTIMENT ET DU SERVICE DES INCENDIES AU SUJET DES RESTRICTIONS ET DES INSPECTIONS D'INSTALLATION DANS VOTRE RÉGION. UN DÉGAGEMENT MINIMAL DE 18 POUCES (457mm) JUSQU'AU RACCORD DE LA CHEMINÉE PEUT ÊTRE EXIGÉ PAR L'AUTORITÉ AYANT JURIDICTION.

PROLONGEMENT D'ÂTRE/PROTECTION DU PLANCHER COMBUSTIBLE: SI INSTALLÉ SUR UN PLANCHER COMBUSTIBLE, L'APPAREIL DOIT ÊTRE PLACÉ SUR UNE PLAQUE PROTECTRICE INCOMBUSTIBLE S'ÉTENDANT SUR 18" (455mm) À L'AVANT ET 8" (205mm) À L'ARRIÈRE ET SUR LES CÔTÉS.

TYPE DE CHEMINÉE: DIAMÈTRE MINIMAL DE 6" (152mm) APPROUVÉE POUR USAGE RÉSIDENTIEL. MAISON MOBILE EMPLOYEZ UNE CHEMINÉE HOMOLOGUÉE ULC S629 AU CANADA OU UL 103HT AUX ÉTATS-UNIS.

RACCORD DE CHEMINÉE: DIAMÈTRE DE 6" (152mm) D'ACIER DE CALIBRE 24 MINIMUM. 18" (455mm) DE DÉGAGEMENT MINIMAL ENTRE LE RACCORD HORIZONTAL ET LE PLAFOND. NE RIEN ENTREPOSER SOUS L'APPAREIL. DES MÉTHODES SPÉCIALES SONT REQUISES LORSQU'UNE CHEMINÉE TRAVERSE UN MUR OU UN PLAFOND. VOIR LES INSTRUCTIONS ET LES CODES DU BÂTIMENT. NE PAS RACCORDER À LA CHEMINÉE D'UN AUTRE APPAREIL.

COMBUSTIBLE: POUR USAGE AVEC LE BOIS SEULEMENT. N'UTILISEZ PAS DE CHENET OU NE SURÉLEVEZ PAS LE BOIS. PRÉPAREZ LE FEU DIRECTEMENT SUR L'ÂTRE.

AVERTISSEMENT: RISQUE D'ÉCHAPPEMENT DE FUMÉE. TENIR LA PORTE FERMÉE LORSQUE LE POÊLE FONCTIONNE. REMPLACEZ LA VITRE PAR UNE VITRE EN CÉRAMIQUE SEULEMENT. NE SURCHAUFFEZ PAS L'APPAREIL. SI L'APPAREIL OU LES RACCORDS ROUGEIOIENT, L'APPAREIL SURCHAUFFÉ. INSPECTEZ ET NETTOYEZ LA CHEMINÉE FRÉQUEMMENT. DANS CERTAINES CONDITIONS, DES DÉPÔTS DE CREOSOTE PEUVENT SE FORMER RAPIDEMENT.

SOUFFLERIE OPTIONNELLE: EP-62, 115V, 60HZ, 0.82A. TENEZ LE CORDON ÉLECTRIQUE LOIN DE L'APPAREIL.

DANGER: RISQUE DE SECOUSSE ÉLECTRIQUE. DÉBRANCHEZ AVANT DE PROCÉDER À L'ENTRETIEN.



IF THE STOVE IS TO BE INSTALLED ON A COMBUSTIBLE FLOOR, IT MUST BE PLACED ON AN APPROVED NON-COMBUSTIBLE HEARTH PAD, THAT EXTENDS 8" (200MM) BEYOND THE STOVE SIDES AND BACK, AND 18" (455MM) TO THE FRONT.

SI LE POÊLE EST INSTALLÉ SUR UN PLANCHER COMBUSTIBLE, IL DOIT ÊTRE PLACÉ SUR UNE BASE DE PROTECTION INCOMBUSTIBLE CERTIFIÉE QUI DOIT DÉPASSER LES CÔTÉS ET L'ÂTRÈRE DU POÊLE DE 8" (200mm) ET SE PROLONGER DE 18" (455mm) SUR LE DEVANT.

MINIMUM CLEARANCE TO COMBUSTIBLE MATERIAL USING SINGLE OR DOUBLE WALL CHIMNEY CONNECTORS / DÉGAGEMENT MINIMAL AUX MATÉRIAUX COMBUSTIBLE AVEC DES CONDUITS DE RACCORDEMENT À PAROI SIMPLE OU À DOUBLE PAROI

FROM HEATER / DU POÊLE
RESIDENTIAL / RÉSIDENTIEL
22IN/PO (560 mm)
12IN/PO (305mm)
8IN/PO (205mm)

CAUTION .HOT WHILE IN OPERATION. DO NOT TOUCH. KEEP CHILDREN, CLOTHING AND FURNITURE AWAY. CONTACT MAY CAUSE SKIN BURNS.

ATTENTION : QUAND L'APPAREIL FONCTIONNE, LA SURFACE DEVIENT CHAUDE. NE PAS TOUCHER. TENIR LES ENFANTS, LES VÊTEMENTS ET LES MEUBLES À L'ÉCART. LE CONTACT PEUT CAUSER DES BRÛLURES À LA PEAU.

U.S. ENVIRONMENTAL PROTECTION AGENCY Certifié conforme à la norme d'émission de particules de juillet 1992.

MADE IN CANADA BY / FABRIQUÉ AU CANADA PAR:
WOLF STEEL LTD., BARRIE, ONTARIO, CANADA

EPA1900

DATE CODE / DE DATE
W385-0402_C

3.0 PRE-INSTALLATION PREPARATION

3.1 APPLIANCE PLACEMENT

Have an authorized dealer install the appliance. If you install the appliance yourself, have your dealer review your installation plans and/or installation.

Draw out a detailed plan of the installation including dimensions and verify the dimensions with the requirements listed in this manual.

You may wish to adjust the appliance position slightly to ensure the vent does not intersect with a framing member. Appliance must be positioned so that no combustibles are within, or can swing within (e.g. drapes, doors), 48" of the front of the appliance.

If the appliance is placed in a location where the ceiling height is less than 7' above the base of the appliance, the installation must follow the requirements in the section "ALCOVE INSTALLATION".

67.1

3.2 CLEARANCE TO COMBUSTIBLES

! WARNING

DO NOT INSTALL INTO ANY AREA HAVING A HEIGHT LESS THAN 7 FEET (CEILING OF ENCLOSURE TO APPLIANCE BOTTOM, EXCLUDING HEARTH HEIGHT).

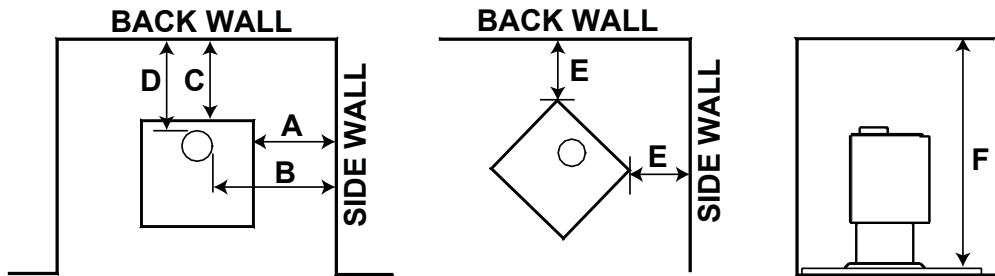

PARALLEL & CORNER	SINGLE WALL CONNECTOR	DOUBLE WALL CONNECTOR
SIDEWALL (A)	22"	22"
SIDEWALL TO FLUE (B)	31 3/4"	31 3/4"
BACK WALL (C)	12"	12"
BACK WALL TO FLUE (D)	15 1/2"	15 1/2"
CORNER (E)	8"	8"
CEILING (F)	84"	84"

Clearances can be reduced with shielding acceptable to local authorities. Reduced installation must comply with NFPA 211 or CAN/CSA-B365.

3.3 FLOOR PROTECTION

If the appliance is to be installed on top of a combustible floor, it must be guarded by a non-combustible material extending at least 18" from the front and 8" from the sides and back of the appliance, see "CLEARANCE TO COMBUSTIBLES" section.

Refer to local building codes for suitable floor protection materials.

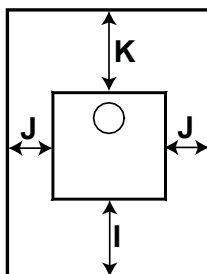

MINIMUM FLOOR PROTECTION			
	FRONT (I)	SIDES (J)	BACK (K)
CANADA	18"	8"	8"
USA	16"	8"	8"

NOTE: If a section of horizontal chimney connector is used, floor protection is required under the chimney connector and 2" beyond each side.

3.4 OUTSIDE AIR

! WARNING

IF ROOM AIR STARVATION OCCURS BECAUSE THE FRESH AIR INTAKE IS BLOCKED WITH ICE, LEAVES, ETC., OR BECAUSE THE APPLIANCE DOOR WAS LEFT OPEN, OR DUE TO A STRONG EXHAUST FAN OPERATING ETC., DANGEROUS FUMES AND SMOKE FROM THE OPERATING APPLIANCE COULD BE DRAWN INTO THE ROOM.

The following are signs that a fresh air kit may be required:

- When there is combustion present: Wood burns poorly, smoke spills, back-draft takes place and your chimney does not draw steadily.
- In the winter there is too much condensation on the windows.
- Opening a window seems to alleviate the above symptoms.
- A ventilation system is installed in the house.
- Other devices are present that exhaust house air.
- The house has tight fitting windows and/or is equipped with a well-sealed vapour barrier.

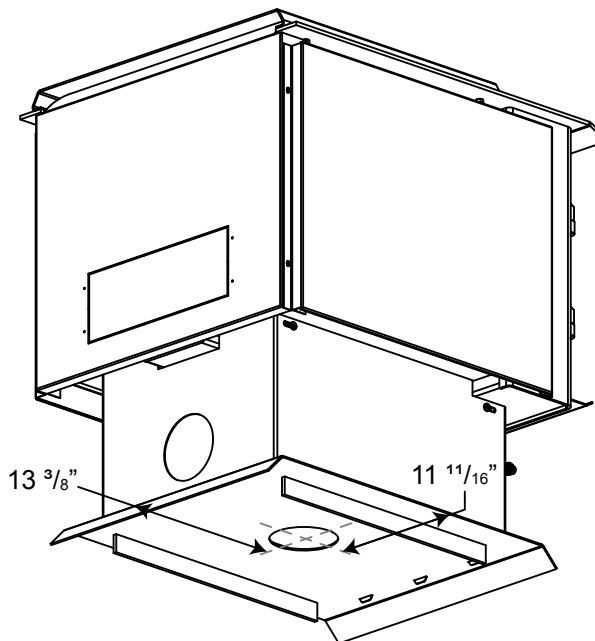

If possible connect the air intake at the pedestal's back or bottom to the outside with a 4 inch diameter fresh air kit available at your authorized dealer / distributor.

4.0 INSTALLATION

WARNING

WEAR GLOVES AND SAFETY GLASSES FOR PROTECTION.

CAREFULLY FOLLOW THE INSTRUCTIONS FOR ASSEMBLY OF THE PIPE AND OTHER PARTS NEEDED TO INSTALL THE APPLIANCE. FAILURE TO DO SO MAY RESULT IN A FIRE, ESPECIALLY IF COMBUSTIBLES ARE TOO CLOSE TO THE APPLIANCE OR CHIMNEY AND AIR SPACES ARE BLOCKED, PREVENTING THE FREE MOVEMENT OF COOLING AIR.

DO NOT DRAW OUTSIDE AIR FROM GARAGE SPACES. EXHAUST PRODUCTS OF GASOLINE ENGINES ARE HAZARDOUS.

DO NOT INSTALL OUTSIDE AIR DUCTS SUCH THAT THE AIR MAY BE DRAWN FROM ATTIC SPACES, BASEMENTS OR ABOVE THE ROOFING WHERE OTHER HEATING APPLIANCES OR FANS AND CHIMNEYS EXHAUST OR UTILIZE AIR. THESE PRECAUTIONS WILL REDUCE THE POSSIBILITY OF APPLIANCE SMOKING OR AIR FLOW REVERSAL.

THE OUTSIDE AIR INLET MUST REMAIN CLEAR OF LEAVES, DEBRIS ICE AND/OR SNOW. IT MUST BE UNRESTRICTED WHILE APPLIANCE IS IN USE TO PREVENT ROOM AIR STARVATION WHICH CAN CAUSE SMOKE SPILLAGE AND AN INABILITY TO MAINTAIN A FIRE. SMOKE SPILLAGE CAN ALSO SET OFF SMOKE ALARMS.

NEGATIVE PRESSURE WITHIN YOUR HOME MAY INADVERTENTLY AFFECT YOUR APPLIANCE.

TO PREVENT CONTACT WITH SAGGING OR LOOSE INSULATION, THE APPLIANCE MUST NOT BE INSTALLED AGAINST VAPOUR BARRIERS OR EXPOSED INSULATION. LOCALIZED OVERHEATING COULD OCCUR AND A FIRE COULD RESULT.

DO NOT USE MAKESHIFT COMPROMISES DURING INSTALLATION. DO NOT BLOCK OR RESTRICT AIR, GRILLE OR LOUVRE OPENINGS. DO NOT ADD A HOOD.

68.3

4.1 CHIMNEY

! WARNING
NEVER INSTALL A SINGLE WALL SLIP SECTION OR SMOKE PIPE IN A CHASE STRUCTURE. THE HIGHER TEMPERATURE OF THIS SINGLE WALL PIPE MAY RADIATE SUFFICIENT HEAT TO COMBUSTIBLE CHASE MATERIALS TO CAUSE A FIRE.
DO NOT CONNECT THIS APPLIANCE TO A CHIMNEY SYSTEM SERVING ANOTHER APPLIANCE.
TO AVOID DANGER OF FIRE, ALL INSTRUCTIONS MUST BE STRICTLY FOLLOWED, INCLUDING THE PROVISION OF AIR SPACE CLEARANCE BETWEEN CHIMNEY SYSTEM AND ENCLOSURE. TO PROTECT AGAINST THE EFFECTS OF CORROSION ON THOSE PARTS EXPOSED TO THE WEATHER, WE RECOMMEND THAT THE CHASE TOP BE PAINTED WITH A RUST-RESISTANT PAINT.
DO NOT FILL ANY FRAMED SPACE AROUND THE CHIMNEY WITH INSULATION OR ANY OTHER MATERIAL. INSULATION PLACED IN THIS AREA COULD CAUSE ADJACENT COMBUSTIBLES TO OVERHEAT.
MAINTAIN A MINIMUM 2" AIR CLEARANCE TO ALL PARTS OF THE CHIMNEY SYSTEM AT ALL TIMES. FAILURE TO MAINTAIN THIS 2" AIR CLEARANCE WILL CAUSE A STRUCTURE FIRE. NEVER FILL THIS SPACE WITH ANY TYPE OF MATERIAL.
DETAILED INSTRUCTIONS FOR INSTALLATION OF THE CHASE TOP, STORM COLLAR AND TERMINATION CAP ARE PACKAGED WITH THESE PARTS.
DO NOT CUT RAFTERS OR CEILING JOISTS WITHOUT FIRST CONSULTING A BUILDING OFFICIAL TO ENSURE STRUCTURAL INTEGRITY IS NOT COMPROMISED.
FIRESTOP SPACERS MUST BE USED WHENEVER THE CHIMNEY PENETRATES A CEILING/FLOOR AREA.
THE TOTAL HORIZONTAL VENT LENGTH SHOULD NOT EXCEED 40% OF THE CHIMNEY HEIGHT ABOVE THE STOVE. ALL HORIZONTAL SMOKE PIPE MUST SLOPE SLIGHTLY UPWARDS A MINIMUM OF 1/4" PER FOOT AND ALL CONNECTIONS MUST BE TIGHT AND SECURED BY THREE SHEET METAL SCREWS EQUALLY SPACED. AN UNINSULATED SMOKE PIPE SHALL NOT PASS THROUGH AN ATTIC, ROOF SPACE, CLOSET OR SIMILAR CONCEALED SPACE, OR THROUGH A FLOOR, CEILING, WALL OR PARTITION, OR ANY COMBUSTIBLE CONSTRUCTIONS.
DO NOT USE ANY MAKESHIFT MATERIALS DURING INSTALLATION.

Your appliance may be hooked up with a factory built or masonry chimney. If you are using a factory built chimney, it must comply with ULCS629 (Canada) or UL103 (USA) standards. It must therefore be a 6" HT Type (2100°F) chimney. It is extremely important that it be installed according to the manufacturer's specifications. The manufacturer's installation instructions and specified clearances should always be followed in accordance with local and national codes. In Canada the CSA B365 and the CSA C22.1 installation codes are to be followed. In the USA the ANSI NFPA 70 and ANSI NFPA 211 installation codes are to be followed.

Chimney and chimney connector must be in good condition and kept clean.

4.1.1 CHIMNEY CONNECTION

Your chimney connector and chimney must have the same diameter as the appliance's exhaust outlet. The appliance pipe must be made of aluminized or cold roll steel with a minimum 24 gauge thickness. It is strictly forbidden to use galvanized steel.

A 6" diameter single wall stove pipe, used to connect the appliance to the chimney, must be installed with the crimped end toward the appliance. This will ensure that the moisture which condenses from the burning wood will flow back into the fire chamber. Each joint in the stove pipe must be secured with at least three sheet metal screws.

For installation of your chimney connector, the following recommendations may be useful.

- The chimney connector must be short and straight. For optimum performance it is recommended that all horizontal runs have a minimum 1/4" rise per foot, with the upper end of the section toward the chimney. For safe and proper operation of the appliance, see "INSTALLATION" instructions.
- To insure a good draft, the total horizontal length of the connector should never exceed 8' to 10'. In the case of vertical installation, the total length of the connector can be longer and connected without problem to the chimney at the ceiling level.
- There should never be more than two 90° elbows in the whole connector and chimney system. Never start with a 90° elbow. Always go up vertically for at least 2 feet from the flue collar before using a 90° elbow.
- The connector must not pass through any combustible material, nor may it pass through a concealed space (such as an attic, roof space, or closet). If passing through a wall, ceiling, or into a masonry chimney, use either chimney components listed for that specific use, or means acceptable to local authorities having jurisdiction over the installation.

This appliance must be connected to:

- A chimney complying with the requirements for Type HT chimneys in the Standard for Chimneys, Factory-Built, Residential Type and Building Heating Appliance, or
- A code-approved masonry chimney with a flue liner. Vent the stove into a masonry chimney or an approved, insulated solid-fuel stainless-steel chimney with as short and straight a length of 6" diameter chimney connector as possible. Connection to a masonry chimney must be by a metal or masonry thimble cemented in place.

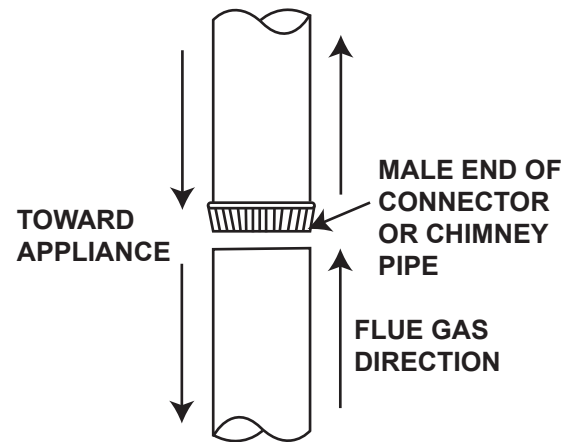

58.1A

4.1.2 ADDING SECTIONS

Add chimney sections, according to the manufacturers installation instructions. The chimney must extend at least, 3 feet above its point of contact with the roof and at least 2 feet higher than any wall, roof or building within 10 feet horizontally.

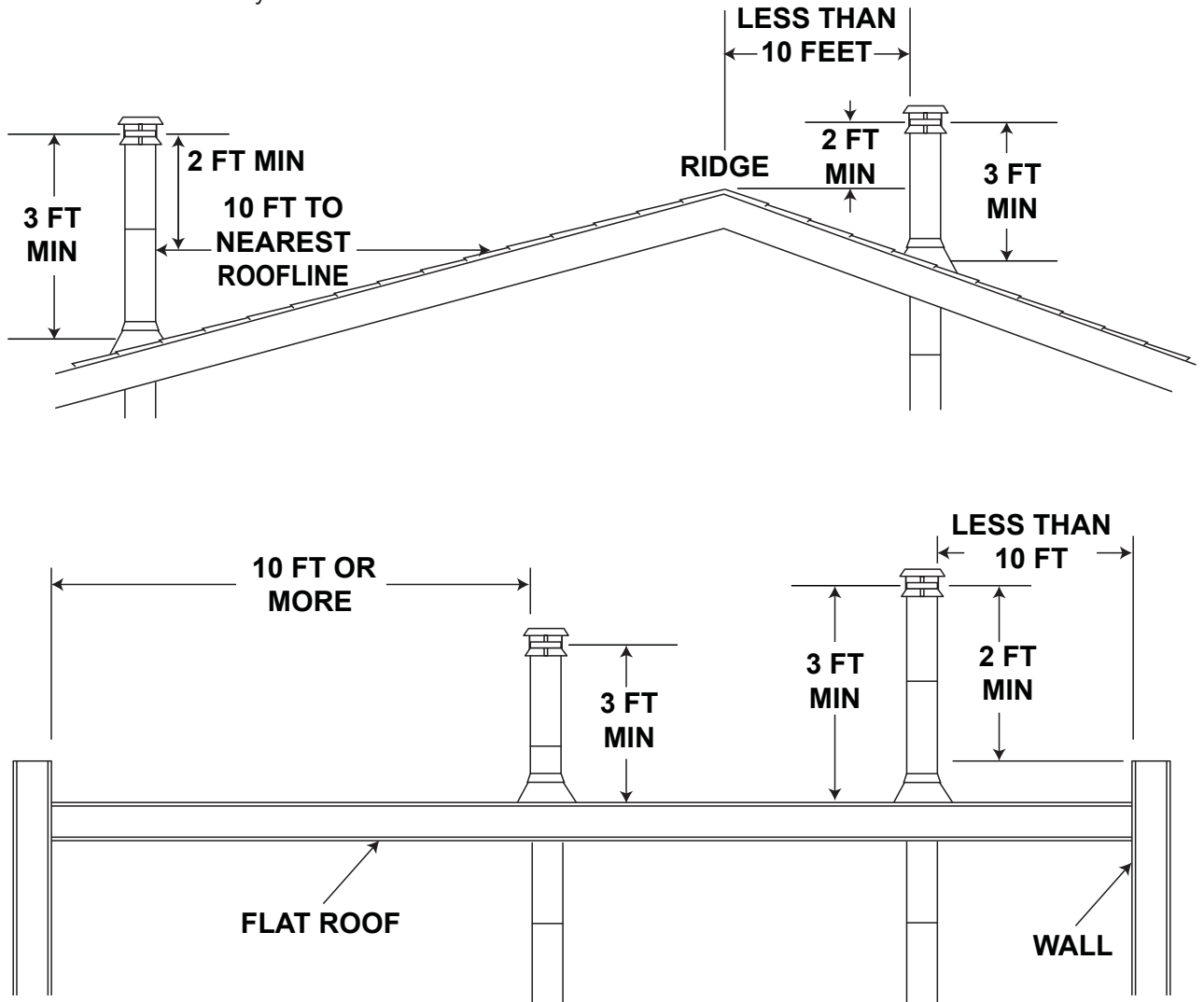

59.1A

4.1.3 TYPICAL THROUGH THE CEILING

A. Move the stove into position with the flue centered, midpoint between two joists to prevent having to cut them. Use a plumb bob to line up the center.

B. Cut and frame an opening in the ceiling to provide a 2" clearance between the outside of the chimney and any combustible material. **DO NOT FILL THIS SPACE WITH ANY TYPE OF MATERIAL.**

Nail headers between the joist for extra support. Firestop spacers must be placed on the bottom of each framed opening in any floor or ceiling that the chimney passes through. If your chimney system is enclosed within the attic area, a rafter radiation shield is required.

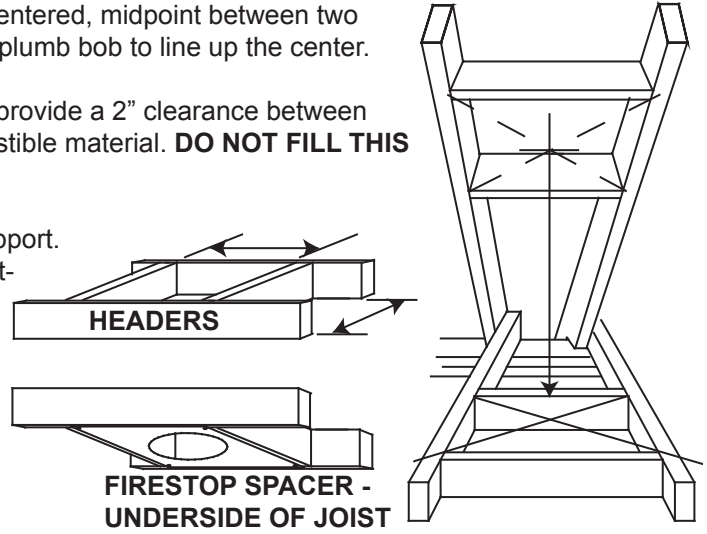

C. Hold a plumb bob from the underside of the roof to determine where the opening in the roof should be. Cut and frame the roof opening to maintain proper 2" clearances.

NOTE: The chimney must be supported at the ceiling or roof so that its weight does not rest on the appliance and must comply with its manufacturer's instructions.

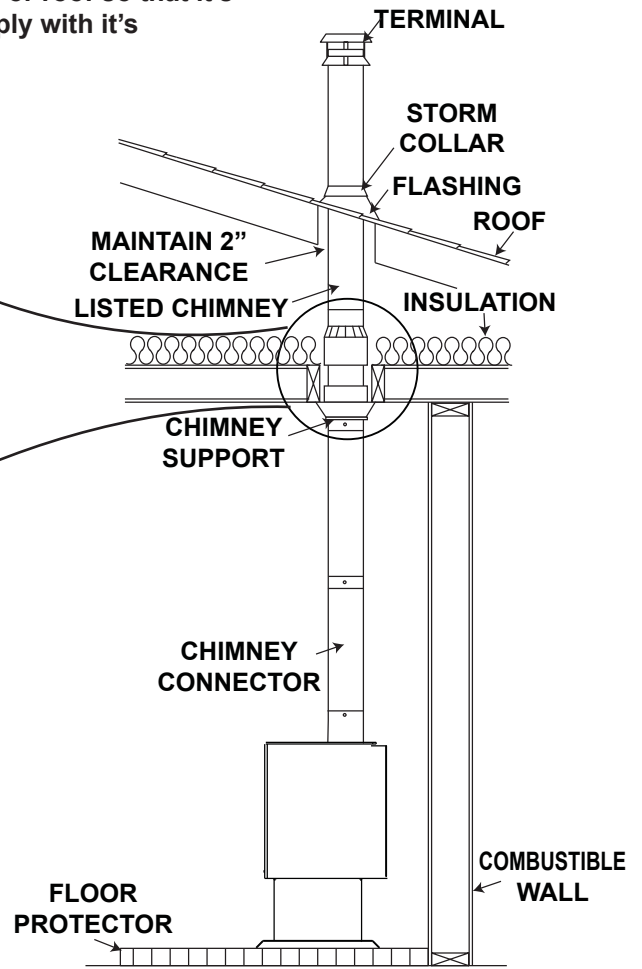
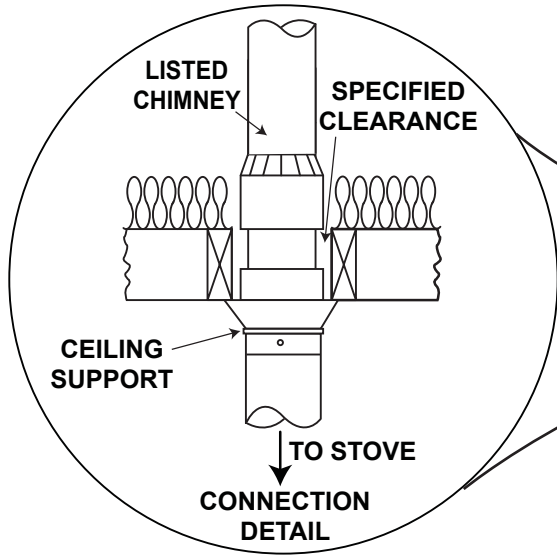

60.1A

4.1.4 TYPICAL THROUGH THE WALL

If possible, design the installation so that the connector does not pass through a combustible wall. If during your installation you must pass through a combustible wall, check with your building inspector before you begin. Also check with the chimney connector manufacturer for any specific requirements.

Consult with your dealer regarding special connection components available for use for wall pass-throughs. Use only parts that have been tested and listed for use in a wall pass-through.

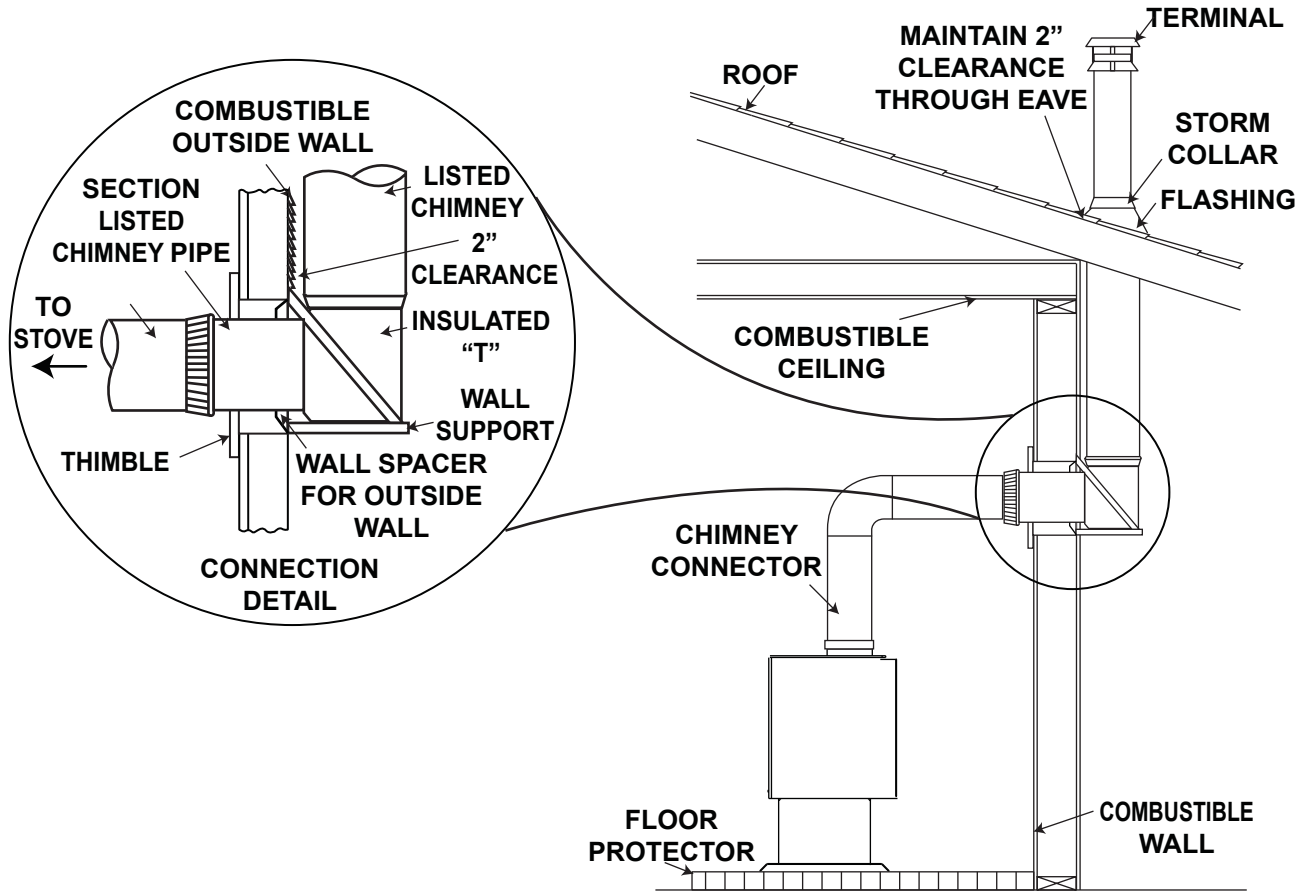

61.1

4.1.5 TYPICAL EXISTING MASONRY

You can also install your appliance using your existing masonry chimney. To do so, follow the guidelines below. You may want to use a factory-built thimble, or construct your own brick thimble. If you are using a masonry chimney, it is important that it be built in compliance with the specifications of the Building Code in your region. It must normally be lined with fire clay bricks, metal or clay tiles sealed together with fire cement. (Round flues are the most efficient). The maximum flue size is 8" x 8" square or 6" round.

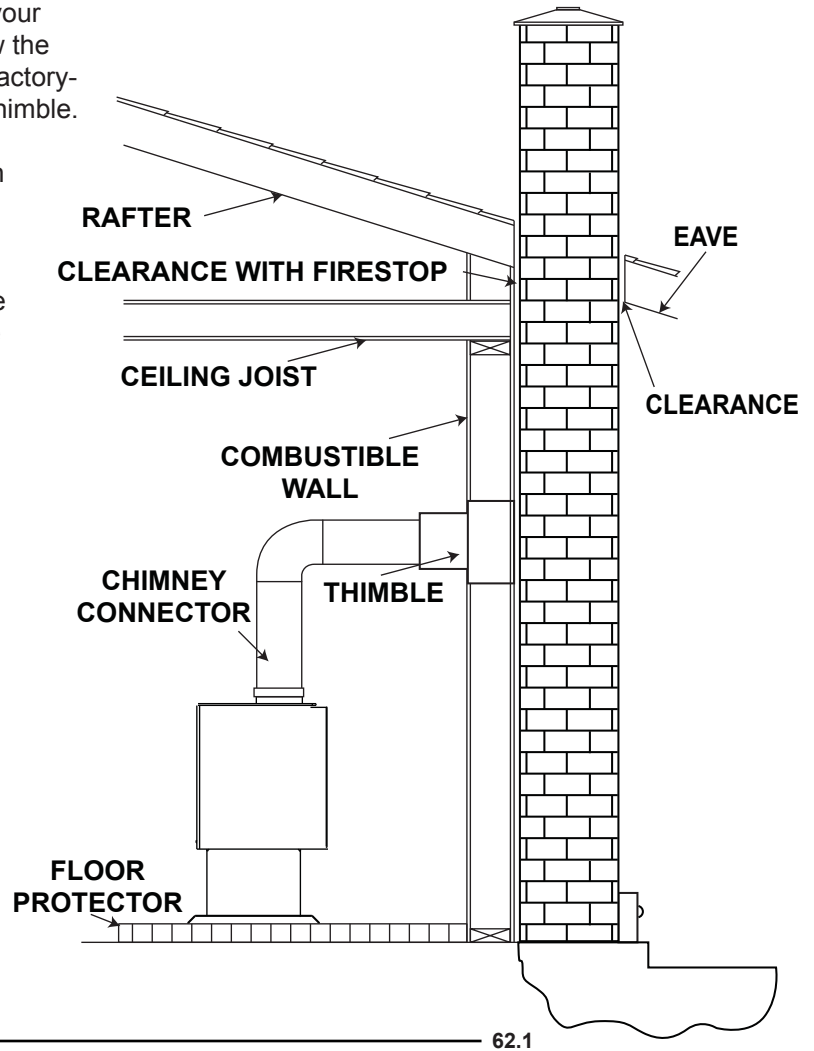

5.0 FINISHING

5.1 DOOR REMOVAL / INSTALLATION

- 5.1.1 Pivot the door open and lift up to clear the bushings. Do not pivot the door any further than necessary.
- 5.1.2 Carefully set the door aside and pull the pins out from the door bushings. Repeat in reverse order to install the door.

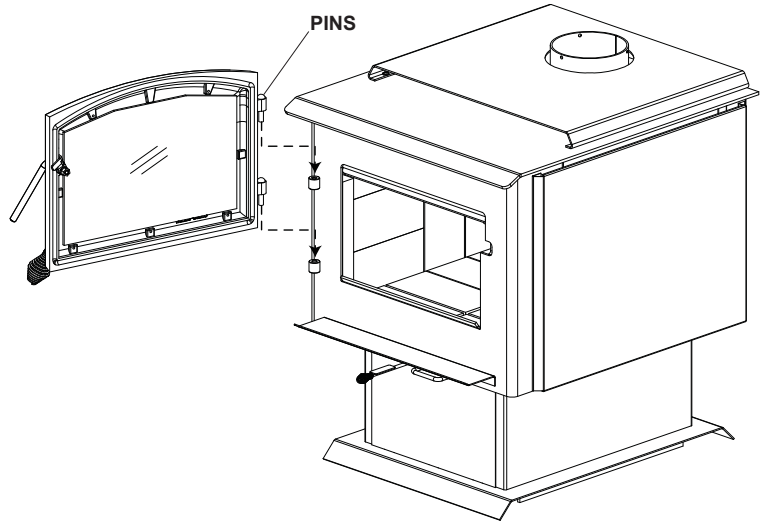

5.2 DOOR HANDLE INSTALLATION

! WARNING

BURNING YOUR APPLIANCE WITH THE DOORS OPEN OR AJAR CREATES A FIRE HAZARD THAT MAY RESULT IN A HOUSE AND OR CHIMNEY FIRE.

DO NOT STRIKE OR SLAM DOOR.

NEVER REMOVE THE DOOR WHEN THE APPLIANCE IS HOT.

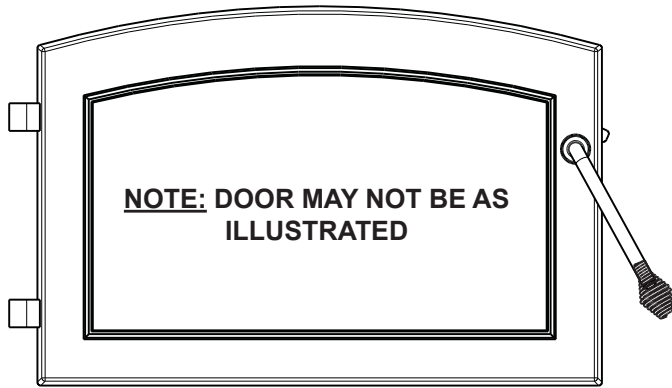

FRONT VIEW

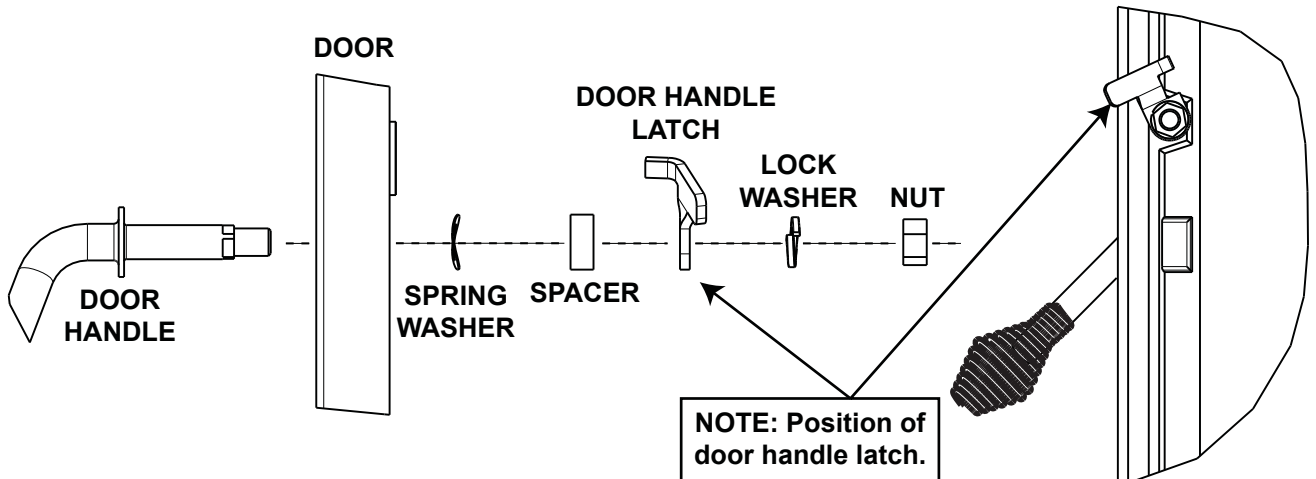

5.3 BRICKS AND BAFFLE INSTALLATION

! WARNING

OPERATION OF THE APPLIANCE WITHOUT THE BAFFLES CAN RESULT IN EXCESSIVE TEMPERATURES THAT COULD DAMAGE THE APPLIANCE, CHIMNEY AND THE SURROUNDING ENCLOSURE.

With stove and chimney installation completed, move the bricks into place as illustrated.

- 5.3.1** Install three courses of brick on both sides of the unit. Install two courses on the back wall. Before installing the final two bricks on the back wall, loosen the screw holding the retainer and ensure that it has been moved forward. Insert the final two bricks behind the retainer and while still holding the bricks in place, slide the retainer snugly into place. Retighten the screw.
- 5.3.2** **1900 ONLY:**
Place the stainless steel support onto the top row of the bricks as illustrated. Pivot the 2 piece baffle up and onto the support, then slide them over and onto the flange of the manifold. Ensure that the overlaps are interlocked to close the gap. Push the baffles to the rear of the firebox. Repeat for the opposite side.
- 5.3.3** Carefully pivot fibre baffle up onto the top of the side brick. Slide it over onto the flange of the manifold. Ensure that the top baffles are pushed all the way to the rear of the firebox, leaving a minimum of a 1 inch gap along the front. This will allow the flue gases to escape the firebox.
- 5.3.4** Install the bottom bricks, working from the back of the unit.
- 5.3.5** Install the 4 bricks at the front as illustrated.

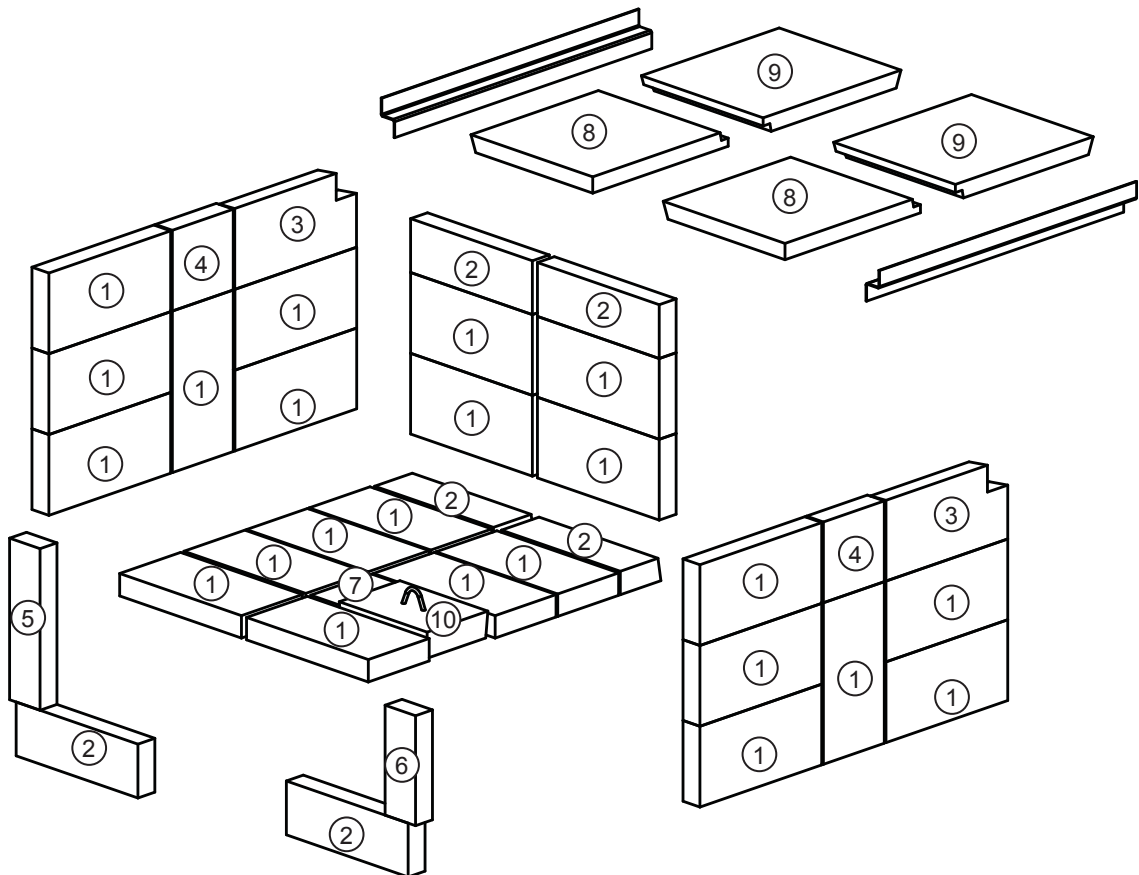

VORTEX BAFFLE ADDENDUM

The following sections of your installation manual have been updated as a continuous improvement. Please refer to the instructions below in place of those in your installation manual.

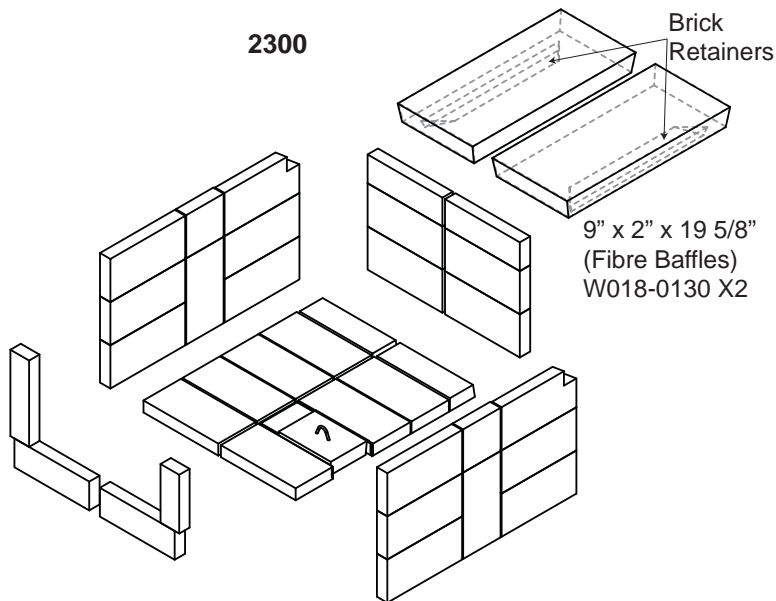

With appliance and chimney installation completed, move the bricks into place for your appliance as illustrated.

- A. Install the bottom bricks, working from the back of the appliance forward.
- B. Before installing the back bricks, loosen the screw holding the brick retainer and ensure that it has been moved forward. Install the six bricks along the back wall by pivoting the bricks up under the brick retainer. Retighten the screw.
- C. Referring to the appropriate illustration for your appliance, install the first two rows of side bricks as shown. Pivot fibre baffle into place, with the brick retainer down and towards the outside of the unit. Slide top row of bricks into place to support the baffle. Baffle must sit flat on outside row of bricks as well as the flange on the manifold shield. Push baffle all the way to the rear of the firebox, leaving a minimum of a 1" gap along the front. This will allow flue gases to escape the firebox.
- D. Install the 4 bricks along the front opening.

NOTE: Do not operate if baffle and manifold shield are not in position.

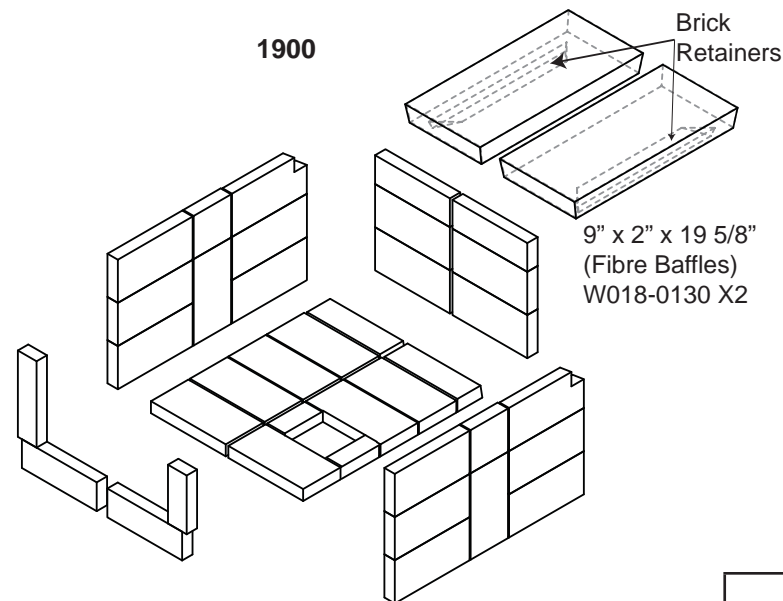

USE THIS ADDENDUM WITH THE FOLLOWING REVISION LEVELS OR EARLIER		
MANUAL #	ENGLISH REVISION	FRENCH REVISION
W415-0763	Ae / 11.03.10	Af / 11.17.10
W415-0892	-e / 03.05.10	-f / 09.01.10

6.0 OPTIONAL KIT INSTALLATIONS

6.1 OPTIONAL BLOWER INSTALLATION

! WARNING

RISK OF FIRE AND ELECTRICAL SHOCK.

TURN OFF THE ELECTRICAL POWER BEFORE SERVICING THIS APPLIANCE.

USE ONLY WOLF STEEL APPROVED OPTIONAL ACCESSORIES AND REPLACEMENT PARTS WITH THIS APPLIANCE. USING NON-LISTED ACCESSORIES (BLOWERS, DOORS, LOUVRES, TRIMS, ETC.) COULD RESULT IN A SAFETY HAZARD AND WILL VOID THE WARRANTY AND CERTIFICATION.

ENSURE THAT THE BLOWER'S POWER CORD IS NOT IN CONTACT WITH ANY SURFACE OF THE APPLIANCE TO PREVENT ELECTRICAL SHOCK OR FIRE DAMAGE. DO NOT RUN THE POWER CORD BENEATH THE APPLIANCE.

Drywall dust will penetrate into the blower bearings, causing irreparable damage. Care must be taken to prevent drywall dust from coming into contact with the blower or its compartment. Any damage resulting from this condition is not covered by the warranty policy. Use of the blower increases the output of heat.

Provisions have been made on this appliance to install an optional blower kit (EP65) that comes complete with a variable speed switch to turn the blower ON/OFF, as well as adjusting the blower speed.

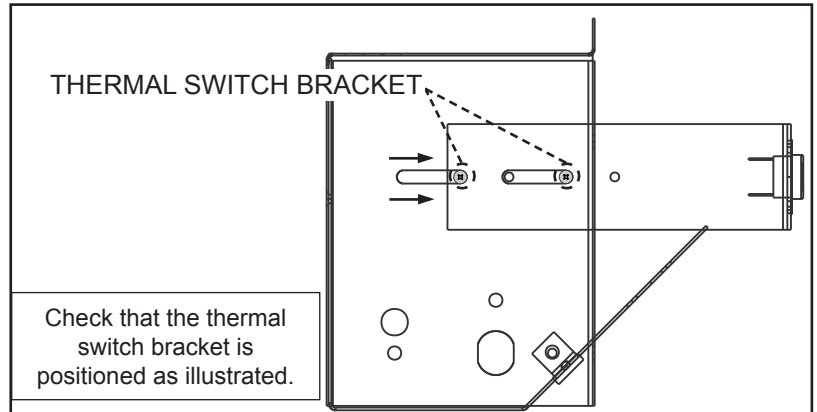

- 6.1.1 Ensure the thermal disc bracket is in the correct position.
- 6.1.2 Remove the knock-out from the back of the appliance.
- 6.1.3 Install the blower and housing as shown using the 4 screws supplied.
- 6.1.4 Loosen the thermal disc bracket (2 screws) and slide the bracket until the thermal disc is touching the rear of the firebox and secure.

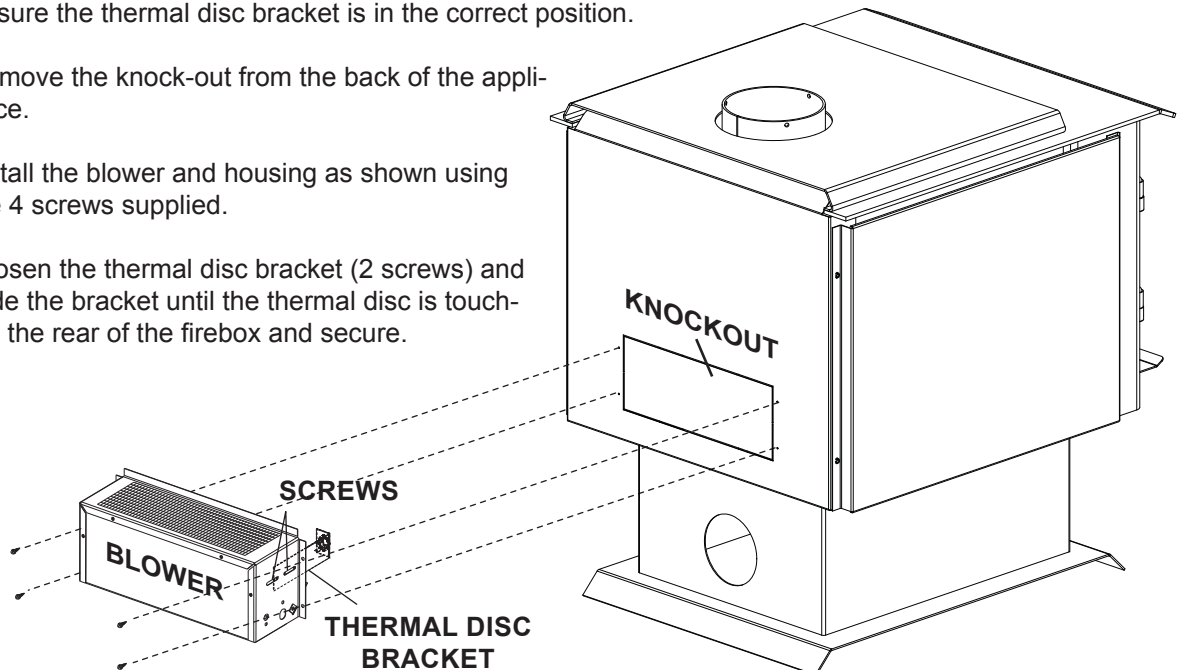

7.0 OPERATION

! WARNING
ALWAYS OPERATE THIS APPLIANCE WITH THE DOOR CLOSED AND LATCHED EXCEPT DURING START UP AND RE-FUELING. ALWAYS WEAR GLOVES TO PREVENT INJURY. DO NOT LEAVE THE FIRE UNATTENDED WHEN THE DOOR IS UNLATCHED AS UNSTABLE WOOD COULD FALL OUT OF THE FIRE CHAMBER CREATING A FIRE HAZARD TO YOUR HOME.
NEVER LEAVE CHILDREN UNATTENDED WHEN THERE IS A FIRE BURNING IN THE APPLIANCE.
NEVER USE GASOLINE, GASOLINE-TYPE LANTERN FUEL, KEROSENE, CHARCOAL LIGHTER FLUID, OR SIMILAR LIQUIDS TO START OR 'FRESHEN UP' A FIRE IN THIS APPLIANCE. KEEP ALL SUCH LIQUIDS WELL AWAY FROM THE APPLIANCE WHILE IT IS IN USE.
OBJECTS PLACED IN FRONT OF THE APPLIANCE SHOULD BE KEPT A MINIMUM OF 48" FROM THE FRONT FACE.
ANY MODIFICATION OF THE APPLIANCE THAT HAS NOT BEEN APPROVED IN WRITING BY THE TESTING AUTHORITY IS CONSIDERED BREACHING CSA B365 (CANADA) AND ANSI NFPA 211 (USA).
OPEN AIR CONTROL (AND DAMPER WHEN FITTED) BEFORE OPENING FIRING DOOR.
HOT WHILE IN OPERATION, KEEP CHILDREN, CLOTHING AND FURNITURE AWAY. CONTACT MAY CAUSE SKIN BURNS. WEAR GLOVES TO OPERATE YOUR APPLIANCE.
BURNING YOUR APPLIANCE WITH THE DOORS OPEN OR AJAR CREATES A FIRE HAZARD THAT MAY RESULT IN A HOUSE AND OR CHIMNEY FIRE.

Your Timberwolf EPA listed product is a Hi-tech appliance, designed with the most advanced technology. The appliance is extremely airtight.

The first fire(s) in your appliance will be difficult to get going and keep going with little amount of heat being generated. This is a result of the moisture being driven out of the fire brick. Allow 30 to 40 hours of hot fires (temperatures in excess of 500°F - 600°F) before your appliance will perform normally. During the break-in period (the first 2 or 3 fires) create only small, hot fires using kindling; this will allow the firebrick to cure. Do not be alarmed if small hairline cracks develop in the firebrick. This is a normal occurrence and does not pose a safety hazard. The paint may also smell a little for the first few fires as it cures and you may wish to open a door or window to alleviate the smell.

To start, a brisk fire is required. Place loosely crumpled paper on the floor of the appliance and cover with dry kindling. Open the air control fully by sliding control all the way to the right. Light the paper and leave the door slightly ajar (one inch) until all kindling is burning. To maintain a brisk fire, a hot coal bed must be established and sustained.

Slowly add larger wood (2x4 size pieces). Lay the pieces lengthwise from side to side in the hot coal bed with a shallow trench between, so that the primary air can flow directly into this trench and ignite the fuel above. When the fire seems to be at its peak, medium sized logs may be added. Once these logs have caught fire, carefully close the door. (Closing the door too quickly after refueling will reduce the firebox temperature and result in an unsatisfactory burn.) Remember it is more efficient to burn medium sized wood, briskly, and refuel frequently than to load the appliance with large logs that result in a smouldering, inefficient fire and dirty glass.

As soon as the door is closed, you will observe a change in the flame pattern. The flames will get smaller and lazier because less oxygen is getting into the combustion chamber. The flames, however, are more efficient. The flames will remain lazy but become larger again as soon as the firebricks have been heated thoroughly and the chimney becomes heated and provides a good draft. At this point, the roaring fire that you see when the door is opened is wastefully drawing heated room air up the chimney, certainly not desirable. Always operate with the door fully closed once the medium sized logs have caught fire.

You can now add larger pieces of wood and operate the appliance normally. Once the appliance is entirely hot, it will burn very efficiently with little smoke from the chimney. There will be a bed of orange coals in the firebox and secondary flames flickering just below the top baffles. You can safely fill the firebox with wood to the top of the door and will get best burns if you keep the appliance pipe temperatures between 250 degrees Fahrenheit (120 degrees Celsius) and 450 degrees Fahrenheit (270 degrees Celsius). A surface thermometer will help regulate this.

Without a appliance thermometer, you are working blindly and have no idea of how the appliance is operating! An appliance thermometer offers a guide to performance and should be located 14" above the flue collar. Install the thermometer according to manufacturers instructions.

Can't get the fire going?

Use more kindling and paper. Assuming the chimney and vent are sized correctly and there is sufficient combustion air, the lack of sufficiently dry quantities of small kindling is the problem. Thumb size is a good gauge for small kindling diameter.

Can't get heat out of the appliance?

One of two things may have happened. The appliance door may have been closed prematurely and the appliance itself has not reached optimum temperature. Reopen the door and/or draft control to re-establish a brisk fire. The other problem may have been wet wood. The typical symptom is sizzling wood and moisture being driven from the wood.

7.1 AIR CONTROL

Draft is the force which moves air from the firebox up through the chimney. The amount of draft in your chimney depends on the length and diameter of chimney, local geography, nearby obstructions and other factors including the amount of heat generated by the fire which can be measured by an appliance thermometer.

Adjusting the air control regulates the temperature. The draft can be adjusted from a low burn rate with the handle in fully, to a fast burn rate with the handle fully out.

Inadequate draft may cause back-puffing into the room through the appliance and chimney connector points and may cause plugging of the chimney. Too much draft may cause an excessive temperature in the appliance, glowing red appliance parts or chimney connectors or an uncontrollable burn which can lead to a chimney fire or permanent damage to the appliance.

Do not operate your appliance for longer than 30 minutes with the draft control on "HIGH" (fully open).

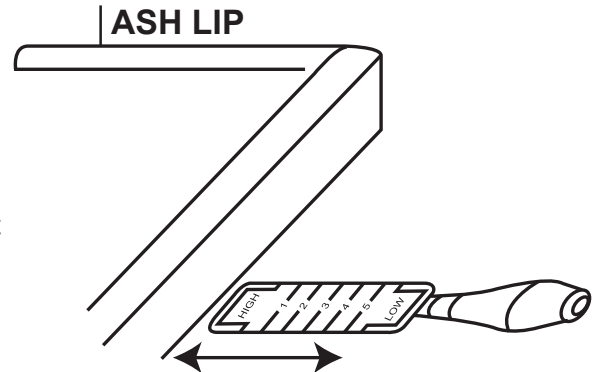

7.2 FIRE EXTINGUISHERS / SMOKE DETECTORS

All homes with a solid fuel burning appliance should have at least one fire extinguisher in a central location known to all, and at least one smoke detector in the room containing the appliance. If it sounds an alarm, correct the cause but do not deactivate or relocate the smoke detector.

7.3 FUEL

WARNING

DO NOT STORE FUEL WITHIN THE CLEARANCE TO COMBUSTIBLES, OR IN THE SPACE REQUIRED FOR RE-FUELING AND ASH REMOVAL.

BURNING WET, UNSEASONED WOOD CAN CAUSE EXCESSIVE CREOSOTE ACCUMULATION. WHEN IGNITED IT CAN CAUSE A CHIMNEY FIRE THAT MAY RESULT IN A SERIOUS HOUSE FIRE.

When loading the appliance, ensure that the two upper fibre baffles are not lifted up and off their ledge. For maximum efficiency, when the appliance is thoroughly hot, load it fully to the top of the door opening and burn at a medium low setting. Maximum heat for minimum fuel (optimum burn) occurs when the appliance top temperature is between 500°F (260°C) and 600°F (315°C). The bricks will be nearly all white and the glass mostly clear. The whiteness of the bricks and the cleanliness of the glass are good indicators of your operating efficiency. Not enough heat is produced when only one or two pieces of wood are burned or the wood may not burn completely. A minimum of three pieces are needed to encase a bed of coals that sustains the fire.

NOTE: When loading the appliance, ensure to keep fuel back from the glass. If coals are to accumulate on the front lip, there is a chance they will fall out when the door is opened.

Loosely stacked wood burns quicker than a tightly packed load. Wood burns in cycles rather than giving a steady output of heat. It is best to plan these cycles around your household routine so that only enough coals are left to start the next load. In the evening, load your appliance, at least, a half-hour before bed to ensure a good fire, hot enough to close the draft control for an overnight burn.

Burn only dry seasoned wood. It produces more heat and less soot or creosote. Do not burn ocean beach wood. Its salt content can produce a metal eating acid. When refueling open the door slowly to prevent smoke spillage. Use a pair of long gloves (barbecue gloves) when feeding the fire. Because these appliances burn at the front, they are clean and efficient, but they are also very hot and gloves are useful. Keep a small steel shovel nearby to use as a poker and to remove ashes. Do not store the wood within 3 feet (1m) of the appliance.

7.4 LIGHTING A FIRE

7.4.1 FLASH FIRE

A flash fire is a small fire burned quickly when you don't need much heat. After your kindling has "caught", load at least 3 pieces of wood, stacked loosely. Burn with the draft control fully open or closed only slightly.

7.4.2 EXTENDED FIRE

Load your larger pieces of wood compactly, packed close enough to prevent the flames from penetrating it completely. After approximately 30 minutes, depending on the size of the load, close the draft control completely making sure that the fire is not extinguished.

DO NOT OVERFIRE THE APPLIANCE!

Overfiring can occur by:

- A. Burning large amounts of smaller wood pieces such as furniture scraps, skids or treated wood;
- B. Vigorously burning large loads of wood with the draft control on "HIGH" (fully open) for long periods of time (one or two hours).
- C. Operating the appliance with the ash dump door blocked open or a poor gasket seal on the main door.

7.5 SMOKING

A properly installed appliance should not smoke. If yours does, check the following:

- Has the chimney had time to get hot?
- Is the smoke passage blocked anywhere in the appliance, chimney connector or chimney?
- Is the room too airtight and the air intake not connected to the outside? Try with a window partly open.
- Is the smoke flow impeded by too long a horizontal pipe or too many bends?
- Is it a weak draft perhaps caused by a leaky chimney, a cold outside chimney, too large a diameter of a chimney, too short a chimney, or a chimney too close to trees or a higher roof?

8.0 MAINTENANCE

! WARNING

TURN OFF THE POWER BEFORE SERVICING THE APPLIANCE.

APPLIANCE MAY BE HOT, DO NOT SERVICE UNTIL APPLIANCE HAS COOLED.

DO NOT USE ABRASIVE CLEANERS.

Check your chimney and chimney connector for creosote and soot buildup weekly until a safe frequency for cleaning is established.

If accumulation is excessive, disconnect the appliance and clean both the chimney and the appliance. You may want to call a professional chimney sweep to clean them. Both have to be cleaned at least once a year or as often as necessary.

Remove fibre baffles and clean above them once a year. Replace any broken bricks.

8.1 ASH REMOVAL PROCEDURES

! WARNING

IMPROPER DISPOSAL OF ASHES RESULT IN FIRES. DO NOT DISCARD ASHES IN CARDBOARD BOXES, DUMP IN BACK YARDS, OR STORE IN GARAGES.

IF USING A VACUUM TO CLEAN UP ASHES, BE SURE THE ASHES ARE ENTIRELY COOLED. USING A VACUUM TO CLEAN UP WARM ASHES COULD CAUSE A FIRE INSIDE THE VACUUM.

NEVER OPERATE YOUR APPLIANCE WITH THE GRATE COVER REMOVED.

FAILURE TO ACHIEVE A GOOD SEAL BETWEEN THE ASH OPENING, ASH PLUG OR ASH WELL DOOR WILL RESULT IN AN OVER FIRE CONDITION THAT COULD CAUSE DAMAGE TO THE APPLIANCE.

Allow the ashes in your firebox to accumulate to a depth of two or three inches; they tend to burn themselves up. When the fire has burned down and cooled, remove any excess ashes but leave an ash bed approximately 1 inch deep on the firebox bottom to help maintain a hot charcoal bed.

DISPOSAL OF ASHES: Ashes should be placed in a metal container with a tight fitting lid. The closed container of ashes should be placed on a non-combustible floor or ground, well away from all combustible materials, pending final disposal. If the ashes are disposed of by burial in soil or otherwise locally dispersed, they should be retained in the closed container until all cinders have thoroughly cooled.

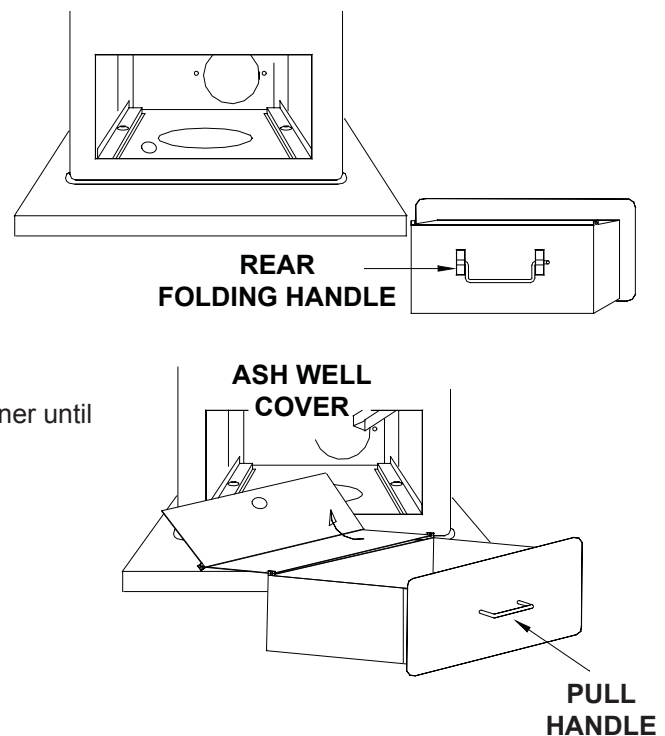

8.2 CREOSOTE FORMATION AND REMOVAL

When wood is burned slowly, it produces tar and other organic vapours which combine with expelled moisture to form creosote. These vapours condense in the relatively cooler chimney flue of a slow burning fire and when ignited, make an extremely hot fire. So, the smoke pipe and chimney should be inspected monthly during the heating season to determine if a buildup has occurred. If creosote has accumulated it should be removed to reduce the risk of a chimney fire.

8.3 RUNAWAY OR CHIMNEY FIRE

Runaway fires can be the result of three major factors:

- Using incorrect fuel, or small fuel pieces which wood normally be used as kindling.
- Leaving the door ajar too long and creating extreme temperatures as the air rushes in the open door.
- Burning your appliance with the ash plug not securely seated.

SOLUTIONS:

- Do not burn treated or processed wood, coal, charcoal, coloured paper or cardboard.
- Be careful not to over-fire the appliance by leaving the door open too long after initial start-up. A thermometer on the chimney connector and/or appliance top helps.
- Always operate the appliance with the ash plug properly installed.

IN CASE OF A CHIMNEY FIRE:

- Have a well understood plan for evacuation and a place outside for everyone to meet. Prepare to evacuate to ensure everyone's safety.
- Close air inlet on appliance.
- Call local fire department. Have a fire extinguisher handy. Contact local authorities for further information on how to handle a chimney fire.
- After the chimney fire is out, clean and inspect the chimney for stress and cracks prior to lighting another fire. Also check combustibles around the chimney and the roof.

8.4 CHIMNEY CLEANING

For serious wood burners, chimney cleaning must be done as needed to avoid chimney fires; the venting systems for controlled combustion appliances may need cleaning as often as once a month. These rates, however, depend on the burning habits of the individual operating the appliance. For example, it is possible to clog a solid fuel appliance chimney in a few days if slow, smoldering fires are burned and the chimney is cold. Wood burners who consistently operate their appliances with appropriately hot fires may infrequently have significant creosote accumulations in the chimney.

Certain items and considerations are important in chimney cleaning:

- Proper tools should be used, including a brush specifically designed for chimney cleaning.
- The chimney connector and dampers as well as the chimney should be cleaned.
- The appliance's firebox and baffle system should be cleaned if needed.
- The chimney should be inspected and repairs made if needed, preferably by a qualified chimney sweep or mason.

8.5 GLASS REPLACEMENT

! WARNING
DO NOT USE SUBSTITUTE MATERIALS.
GLASS MAY BE HOT, DO NOT TOUCH GLASS UNTIL COOLED.
CARE MUST BE TAKEN WHEN REMOVING AND DISPOSING OF ANY BROKEN DOOR GLASS OR DAMAGED COMPONENTS. BE SURE TO VACUUM UP ANY BROKEN GLASS FROM INSIDE THE APPLIANCE BEFORE OPERATION.
DO NOT STRIKE, SLAM OR SCRATCH GLASS. DO NOT OPERATE APPLIANCE WITH GLASS REMOVED, CRACKED, BROKEN OR SCRATCHED.

56.1

- 8.5.1** When the appliance is cool, open the door and place the door frame down careful not to scratch the paint.
- 8.5.2** Remove the screws and brackets holding the glass in place. Remove all broken glass.
- 8.5.3** Wrap the edges of the new glass with a U-shaped strip of fiberglass gasket, covering 1/4" on each side.

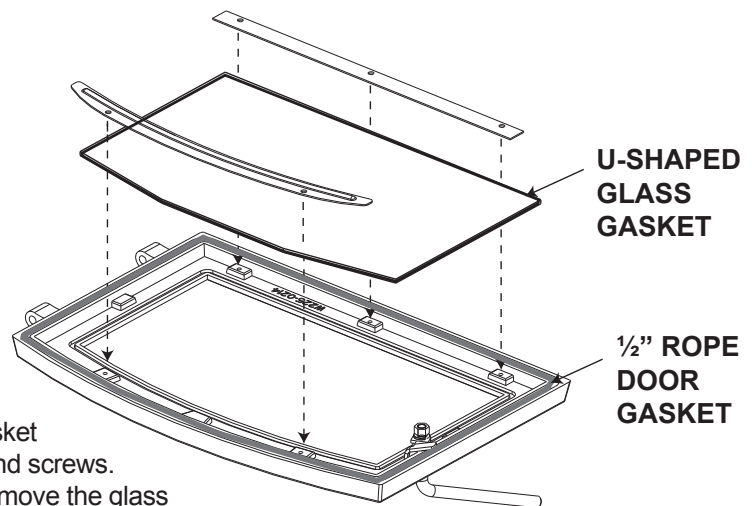

- 8.5.4** Place the glass with the fiberglass gasket in position and replace the brackets and screws. When finished, you should be able to move the glass slightly, horizontally and vertically.

NOTE: For replacement glass, size, thickness and specifications see “REPLACEMENTS” section.

8.6 GASKET REPLACEMENT

At the end of each burning season inspect the shield and gasket below the manifold for warping or deterioration. Replace if necessary. Both are held to the manifold with machine screws. The shield and the 1/8" fibre cloth gasket are available from your Wolf Steel Ltd. dealer. At this time also check that the door gasket is not worn or loose. Replace with 3/8" high density fibreglass rope if necessary.

The airwash gasket and shield above the door should also be inspected and replaced if deteriorated

NOTE: Do not operate appliance if gasket, manifold shield or fibre baffle is deteriorated or missing.

8.7 CARE OF GLASS

If the glass is not kept clean permanent discoloration and / or blemishes may result. Normally a hot fire will clean the glass. The most common reasons for dirty glass include: not using sufficient fuel to get the appliance thoroughly hot, using green or wet wood, closing the draft so far that there is insufficient air for complete combustion.

If it is necessary to clean the glass, buff lightly with a clean dry cloth and non-abrasive cleaner.



DO NOT CLEAN GLASS WHEN HOT! Clean the glass after the first 10 hours of operation with a recommended appliance glass cleaner. Thereafter clean as required.

The glass is very strong but do not let burning fuel rest or fall against it and always close the door gently. **NEVER FORCE IT SHUT!**

If the glass should ever crack or break while the fire is burning, do not open the door until the fire is out and do not operate the appliance again until the glass has been replaced, available from your Authorized dealer. **DO NOT SUBSTITUTE MATERIALS.**

5.3

8.8 CARE OF PLATED PARTS

If the appliance is equipped with plated parts, you must clean fingerprints or other marks from the plated surfaces before operating the appliance for the first time. Use a glass cleaner or vinegar and towel to clean. If not cleaned properly before operating for the first time, the marks can cause permanent blemishes on the plating. After the plating is cured, the fingerprints and oils will not affect the finish and little maintenance is required, just wipe clean as needed. Prolonged high temperature burning with the door ajar may cause discoloration on plated parts.

NOTE: The protective wrap on plated parts is best removed when the assembly is at room temperature but this can be improved if the assembly is warmed, using a hair dryer or similar heat source.

6.1

8.9 WOOD

Fuel for the appliance must not be stored closer than the required clearances to combustibles (heat sensitive material). **NEVER STORE WOOD IN THE ASH PAN COMPARTMENT.**

Burn only dry, clean unpainted wood that has been seasoned. It produces more heat and less soot or creosote. Freshly cut wood contains about 50% moisture while after proper seasoning only about 20% of the water remains. As wood is burned, this water boils off consuming energy that should be used in heating. The wetter the wood, the less heat is given off and the more creosote is produced.

Both hardwood and softwood burn equally well in this appliance but hardwood is denser, will weigh more per cord and burn a little slower and longer. Firewood should be split, stacked in a manner that air can get to all parts of it and covered in early spring to be ready for burning that fall. Dry firewood has cracks in the end grain. Cut the wood so that it will fit horizontally, front to back, making for easier loading and less of a likelihood that the wood will roll onto the glass. Ideal lengths of wood are approximately 21".

DO'S

- Build a hot fire.
- Use only dry wood.
- Several pieces of medium sized wood are better than a few big pieces.
- Clean chimney regularly.
- Refuel frequently using medium sized wood.
- "Fine Tune" the air settings for optimum performance.

DONT'S

- Take ash out immediately. Let it accumulate to a depth of at least one inch. A good ash layer provides for a longer lasting and better burning fire.
- Burn wet wood.
- Close the door too soon or damper down too quickly.
- Burn one large log rather than two or three smaller, more reasonably sized logs.
- Burn at continually "low setting", if glass door is constantly blackened. This means the fire-box temperature is too low.

9.0 REPLACEMENTS

Contact your dealer or the factory for questions concerning prices and policies on replacement parts. Normally all parts can be ordered through your Authorized dealer / distributor.

FOR WARRANTY REPLACEMENT PARTS, A PHOTOCOPY OF THE ORIGINAL INVOICE WILL BE REQUIRED TO HONOUR THE CLAIM.

When ordering replacement parts always give the following information:

- Model & Serial Number of appliance
- Installation date of appliance
- Part number
- Description of part
- Finish

*** IDENTIFIES ITEMS WHICH ARE NOT ILLUSTRATED. FOR FURTHER INFORMATION, CONTACT YOUR AUTHORIZED DEALER.**

 **WARNING**

**FAILURE TO POSITION THE PARTS
IN ACCORDANCE WITH THIS
MANUAL OR FAILURE TO USE ONLY
PARTS SPECIFICALLY APPROVED
WITH THIS APPLIANCE MAY
RESULT IN PROPERTY DAMAGE OR
PERSONAL INJURY.**

41.1

COMPONENTS		
REF NO.	PART NO.	DESCRIPTION
1	W090-0015	BRICK #1
2	W090-0002	BRICK #2
3	W090-0005	BRICK #3
4	W090-0003	BRICK #4
5	W090-0018	BRICK #5
6	W090-0019	BRICK #6
7	W090-0016	BRICK #7
8	W018-0092	#8 FIBRE BAFFLE
9	W018-0093	#9 FIBRE BAFFLE
10	W510-0011	ASH PLUG #10
11	W010-1534	ASH DRAW ASSEMBLY
12	W580-0008	COMPLETE BRICK SET
13	W655-0209	BRICK SUPPORT
14*	W710-0025	ASH TRAY
15	W225-0225	BLACK DOOR
16	W300-0017	GLASS
17	W325-0018	DOOR HANDLE

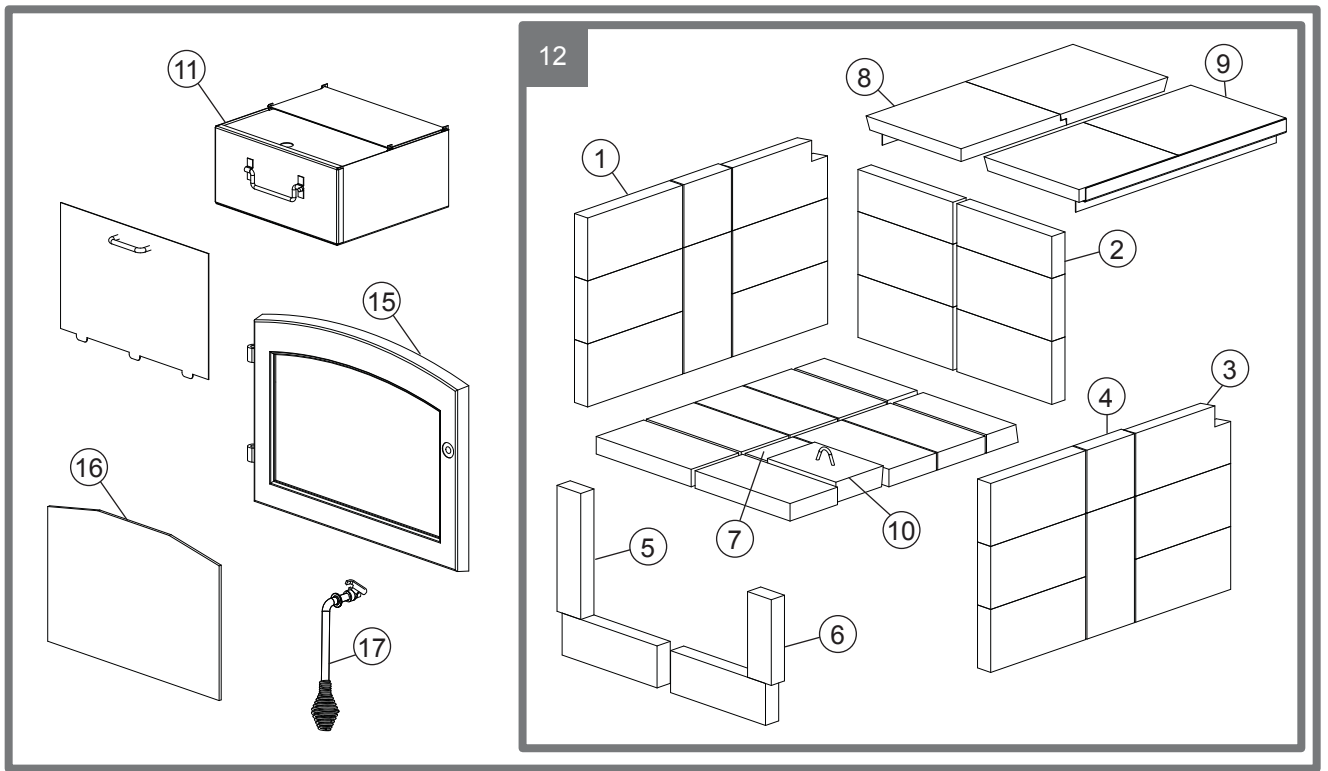

10.0 TROUBLE SHOOTING

WARNING

TURN OFF THE ELECTRICAL POWER BEFORE SERVICING THE APPLIANCE.

APPLIANCE MAY BE HOT, DO NOT SERVICE UNTIL APPLIANCE HAS COOLED.

DO NOT USE ABRASIVE CLEANERS.

WHEN CHECKING CONNECTIONS, INSTALLING JUMPER WIRES (FOR TEST PURPOSES ONLY) OR REPLACING COMPONENTS, UNPLUG HEATER FROM THE RECEPTACLE TO PREVENT ELECTRICAL SHOCK OR DAMAGE TO THE COMPONENT.

PROBLEM	SOLUTION
Can't get the fire.	<ul style="list-style-type: none"> - Not enough kindling / paper? Add more. - Not enough air? Ensure air control is fully open. - Cold air blockage? Burn a piece of paper to establish a draft. - Use dry seasoned wood. - Flue blockage? Inspect chimney.
Smokes when door is open.	<ul style="list-style-type: none"> - Cold air blockage? Burn a piece of paper to establish a draft. - Insufficient draft? Add more pipe. - Let air stabilize before opening door. - Ensure baffles are positioned correctly. - Negative pressure? Open a window near the appliance.
Appliance emits odour.	<ul style="list-style-type: none"> - Paint curing. See "GENERAL INSTRUCTIONS" section.
Stove doesn't burnt hot enough.	<ul style="list-style-type: none"> - Wood is too wet. - Insufficient draft? Add more pipe. - Not enough air? Ensure air control is fully open.
Wood burns too fast.	<ul style="list-style-type: none"> - Air control may need to be adjusted down. - Check to see ash plug is properly seated. - Check door gasket for adequate seal. - Wood may be extremely dry.
Dirty glass.	<ul style="list-style-type: none"> - Air control may be closed too far. - Burn hotter, smaller fires. - Use well seasoned wood.
Blower does not run.	<ul style="list-style-type: none"> - Appliance may not be up to temperature. - Ensure blower has power.

42.14

11.0 WARRANTY

TIMBERWOLF products are manufactured under the strict Standard of the World Recognized ISO 9001 : 2008 Quality Assurance Certificate.

TIMBERWOLF products are designed with superior components and materials, assembled by trained craftsmen who take great pride in their work. The complete appliance is thoroughly inspected by a qualified technician before packaging to ensure that you, the customer, receives the quality product that you expect from TIMBERWOLF.

TIMBERWOLF WOOD APPLIANCE PRESIDENT'S LIMITED WARRANTY

The following materials and workmanship in your new TIMBERWOLF appliance are warranted against defects as defined below:

The combustion chamber is warranted against defects for a period of 25 years.

The secondary air tubes are warranted against defects for a period of five years.

All other wearable parts and electrical components such as blowers, thermal switches, switches, wiring, rheostats, firebrick, ceramic glass (thermal breakage only), fibre baffles and gasketing are covered and Wolf Steel will provide replacement parts free of charge during the first year of the limited warranty.

Any labour related to warranty repair is not covered.

* Construction of models vary. Warranty applies only to components included with your specific heater.

CONDITIONS AND LIMITATIONS

Wolf Steel warrants its TIMBERWOLF products against manufacturing defects to the original purchaser only. Registering your warranty is not necessary. Simply provide your proof of purchase along with the model and serial number to make a warranty claim. Provided that the purchase was made through an authorized TIMBERWOLF dealer your appliance is subject to the following conditions and limitations:

This factory warranty is non-transferable and may not be extended whatsoever by any of our representatives.

The appliance must be installed by an authorized service technician or contractor. Installation must be done in accordance with the installation instructions included with the product and all local and national building and fire codes.

This limited warranty does not cover damages caused by misuse, lack of maintenance, accident, alterations, abuse or neglect. Operating the appliance on high for extended periods of time, is neglect. Parts installed from other manufacturers will nullify this warranty.

This limited warranty further does not cover any scratches, dents, corrosion or discoloring caused by excessive heat, abrasive and chemical cleaners nor chipping on porcelain enamel parts, nor any venting components used in the installation of the appliance.

In the first year only, this warranty extends to the repair or replacement of warranted parts which are defective in material or workmanship provided that the product has been operated in accordance with the operation instructions and under normal conditions.

After the first year, with respect to the TIMBERWOLF'S President's Limited Warranty, Wolf Steel may, at its discretion, fully discharge all obligations with respect to this warranty by refunding to the original warranted purchaser the wholesale price of any warranted but defective parts.

After the first year, Wolf Steel Ltd. will not be responsible for installation, labour or any other costs or expenses related to the reinstallation of a warranted part, and such expenses are not covered by this warranty.

Notwithstanding any provisions contained in the TIMBERWOLF'S President's Limited Warranty, Wolf Steel's responsibility under this warranty is defined as above and it shall not in any event extend to any incidental, consequential or indirect damages.

This warranty defines the obligations and liability of Wolf Steel with respect to the TIMBERWOLF appliance and any other warranties expressed or implied with respect to this product, its components or accessories are excluded.

Wolf Steel neither assumes, nor authorizes any third party to assume, on its behalf, any other liabilities with respect to the sale of this product. Wolf Steel will not be responsible for: over-firing, downdrafts, spillage caused by environmental conditions such as rooftops, buildings, nearby trees, hills, mountains, inadequate vents or ventilation, excessive venting configurations, insufficient makeup air, or negative air pressures which may or may not be caused by mechanical systems such as exhaust blowers, furnaces, clothes dryers, etc.

Any damages to appliance, combustion chamber, heat exchanger or other components due to water, weather damage, long periods of dampness, condensation, damaging chemicals or cleaners will not be the responsibility of Wolf Steel.

Regular cleaning of the fine ash generated during the operation of this appliance is a necessary part of maintaining your appliance. Failure of any components, which is attributed to poor maintenance, is not warrantable and will not be covered by this policy.

Wolf Steel reserves the right to have its representative inspect any TIMBERWOLF product or part thereof prior to honouring any warranty claim.

ALL SPECIFICATIONS AND DESIGNS ARE SUBJECT TO CHANGE WITHOUT PRIOR NOTICE DUE TO ON-GOING PRODUCT IMPROVEMENTS.

2.11_A

